

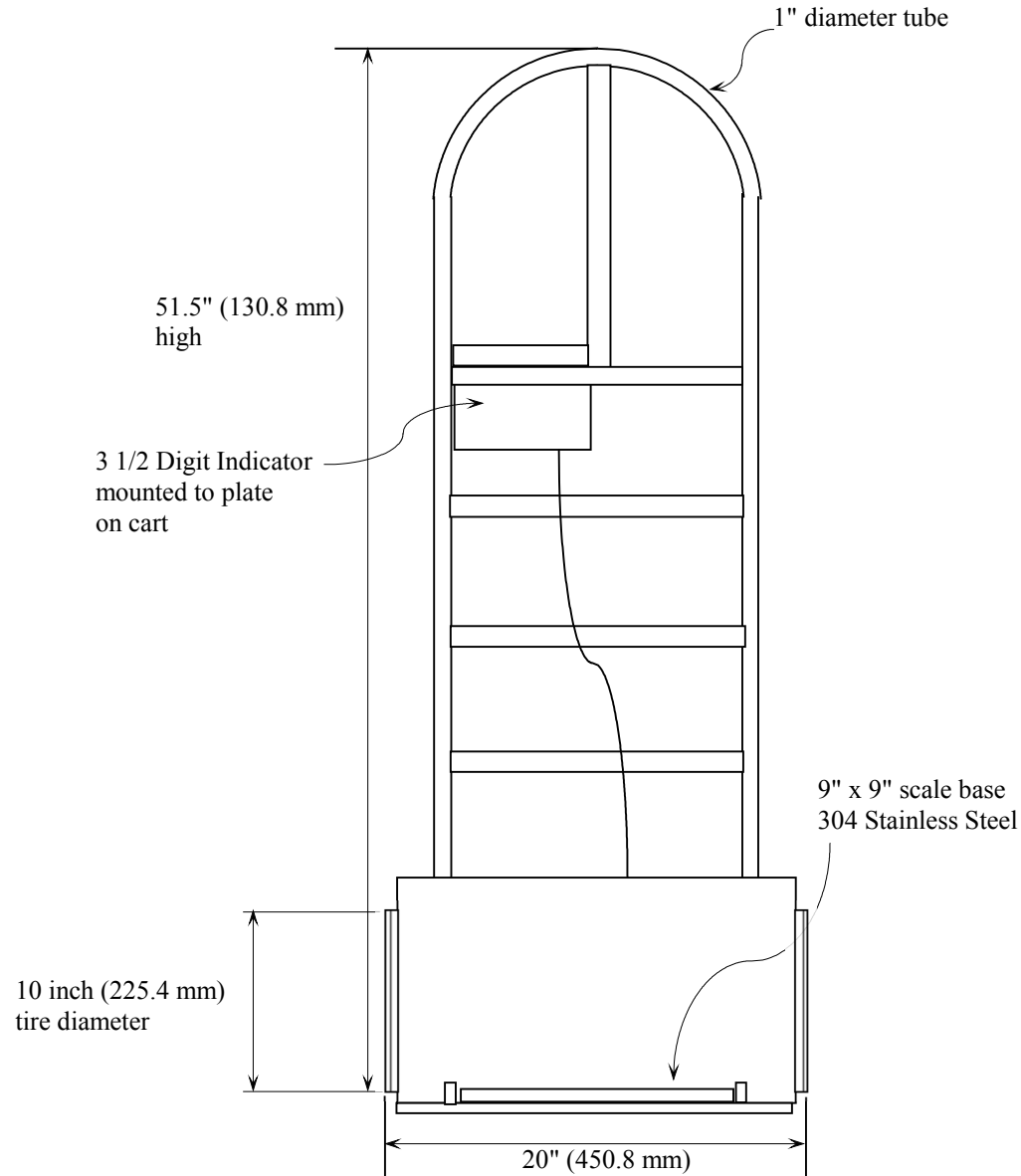

**FRONT VIEW**



TOLERANCES (UNLESS SPECIFIED)  
 .XXX = ±0.005"  
 .XX = ± 0.01"  
 FRACTIONS = ± 1/64"  
 ANGLES = ± 1/2°

REV	DATE	DESCRIPTION	BY

	
Scale: ~	Drawn By: NLG
Date: 9/01/2011	Revised:
Front View of Model 2308CS <sup>TM</sup>	Drawing Number: <b>SK - 171</b>

**SIDE VIEW**

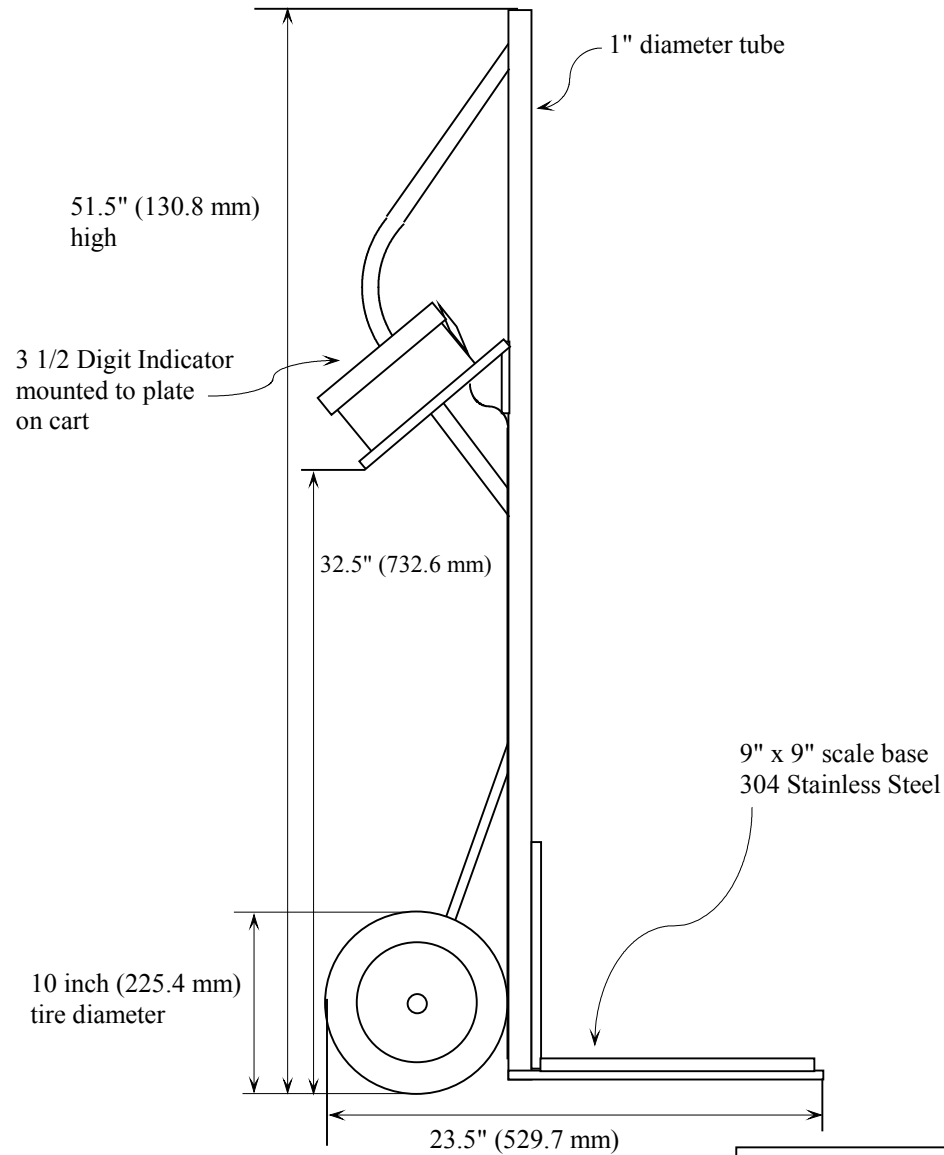

TOLERANCES (UNLESS SPECIFIED)  
 .XXX =  $\pm 0.005"$   
 .XX =  $\pm 0.01"$   
 FRACTIONS  $\pm 1/64"$   
 ANGLES =  $\pm 1/2^\circ$

REV	DATE	DESCRIPTION	BY

Scale: ~	Drawn By: NLG
Date: 9/01/2011	Revised:
Side View of Model 2308CS <sup>TM</sup>	Drawing Number: <b>SK - 172</b>