



**Scaleton™  
Sets The Standard  
In Corrosion  
Resistance**

## Model 2310™ Digital Single Cylinder Scale

- Designed for weighing 12" diameter cylinders (and smaller)
- Base size: 15-3/4"x17-1/2"
- Gross capacity range: 0-349 lbs. (158 kg)
- High accuracy of  $\pm 0.5\%$  of capacity
- Standard indicator: 3-1/2 digit LCD display with easy readability to 1 lb. (kg) or 0.1 lb. (kg)
- Readout in pounds or kilograms
- Sturdy and accurate three point suspension on the weighing platform
- Patented



3-1/2 Digit Controller  
(Standard)



### Standard Features

- Rugged corrosion resistant solid PVC construction for use in harsh environments
- Low profile platform design increases safety and ease of cylinder handling
- Electronic indicator housed in NEMA 4X, UL approved enclosure to provide protection from acids
- Stainless steel load cell
- Self-locking tare adjustment knob
- 4-20 mA output signal – scale or loop powered
- 12 ft. of 4 conductor wire cable
- Cylinder support and chains

### Options

- Low level relay contacts
- Model 1099™ Chemical Process Controller
- Remote mounting of indicator box up to 200 feet (61 meters) away
- Junction box
- Additional length of 4 conductor wire cable

### Chemicals

Scale is designed to accurately measure weight of alum, ammonia, caustic, fluoride, phosphate, polymers, sodium aluminate, sodium bisulfate, sodium hydroxide, sodium hypochlorite and other liquids or powders

### Scaleton Industries Ltd.

Bedminster Industrial Park  
53 Apple Tree Lane • P.O. Box 365  
Plumsteadville, PA 18949 • USA

Tel: (+1) 215-766-2670 (International)  
Tel: (+1) 800-257-5911 (USA & Canada)  
Fax: (+1) 215-766-2672

Email: [info@scaletonscales.com](mailto:info@scaletonscales.com)  
Website: [www.scaletonscales.com](http://www.scaletonscales.com)

# Model 2310™ Digital Single Cylinder Scale General Specifications

**CE** 5 year **FULL** warranty  
on **ALL** products!

## INDICATOR BOX

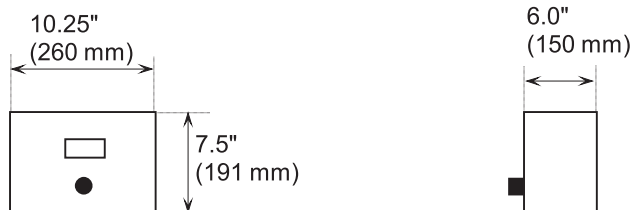

## CYLINDER SUPPORT BAR



## SCALE BASE

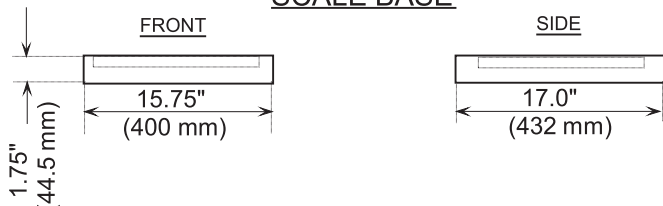

## SCALE BASE - TOP VIEW

(enlarged for detail)

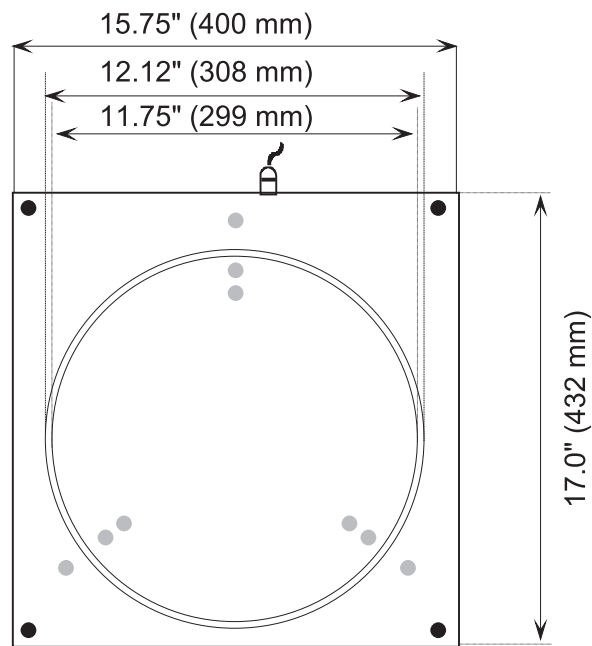

BOLT DOWN HOLES ~ TYPICAL (4) PLACES  
CLEARANCE FOR 3/8" BOLT

<b>Indicator:</b>	<b>3-1/2 Digit</b>
<b>Platform Size:</b>	15-3/4 " (400 mm) wide x 17-1/2" (444 mm) deep
<b>Platform Height:</b>	1-3/4" (44.5 mm)
<b>Gross Capacity:</b>	Up to 349 lbs. (158 kg)
<b>Accuracy:</b>	±0.5% of full capacity
<b>Resolution:</b>	0.1 lb. (kg) up to 199.9 lbs. (kg)
<b>4-20 mA:</b>	Standard – scale or loop powered
<b>Level Indication/ Relay Contacts:</b>	Optional low level REED relay contact(s)
<b>Power:</b>	85 VAC to 265 VAC, 50/60 Hz
<b>Enclosure:</b>	NEMA 4X, UL Approved Enclosure
<b>Shipping Weight:</b>	22 lbs.

## Typical Specifications

Scale must weigh 150 lb. cylinder. The accuracy must be at least 0.5%. Digital readout must be an LCD Display with characters that are 0.5 inches high, with 0.1 lb. or 0.1 kg resolution. Indicator is required to have 4-20 mA output selectable as scale powered or loop powered, standard. Indicator must have a knob to set tare weight. The electronics must be housed in a NEMA 4X, UL approved enclosure. All base hardware must be stainless steel. The cross bar shall be coated with dry powder polyester plastic. The entire base must be PVC to prevent corrosion.

Scale shall be a Model 2310™ as manufactured by Scaleton Industries Ltd., Plumsteadville, PA.