

MODEL 2352™ and 2353™ DUAL CYLINDER ELECTRONIC SCALE

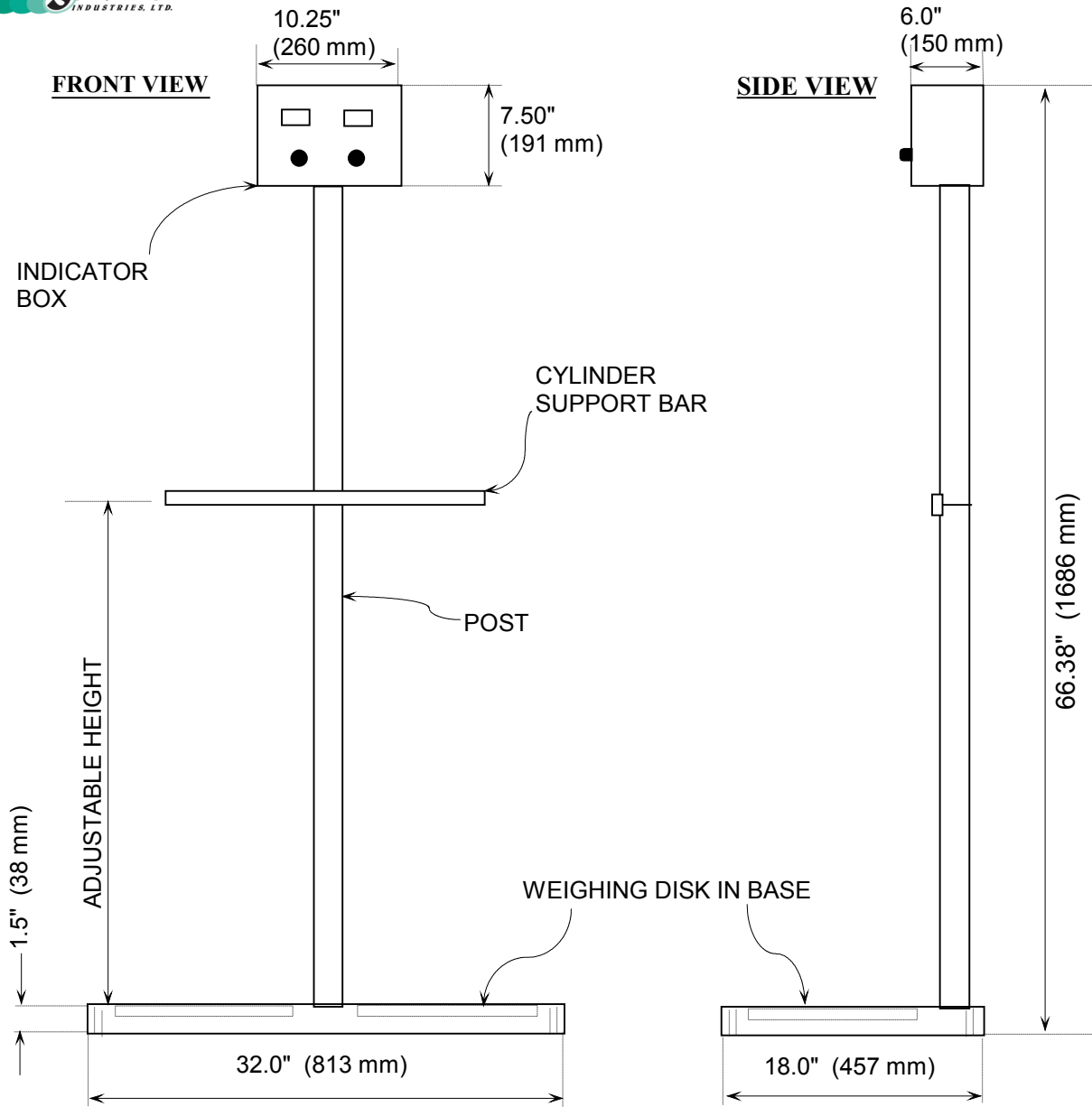

ANCHOR BOLT HOLES FOR 3/8" BOLT (not supplied)
Typical (4) places

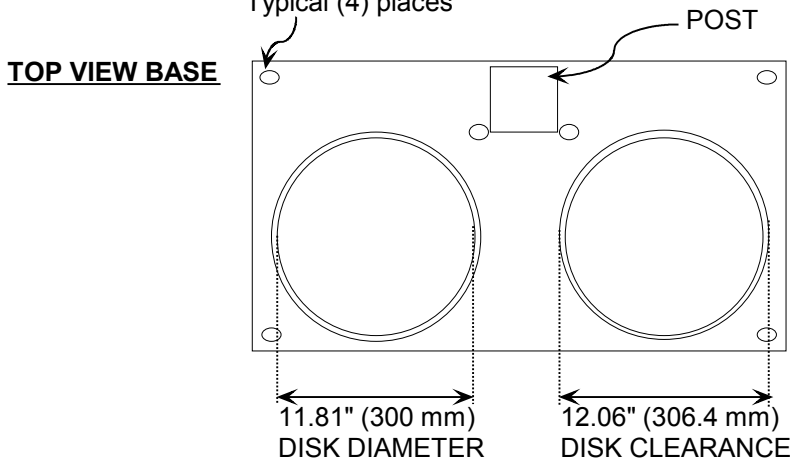

For Model 2352™ :

This model includes, two bases with posts, and a small junction box (4" w x 4" d x 2" h) on the top of post, and wires feed to the indicator box mounted on the wall. Wire connections are established from the junction boxes to the indicator and sealed with liquid tight fittings.

For Model 2353™ :

This model includes, three bases with posts. The two outside bases have a small junction box (4" w x 4" d x 2" h) mounted on the post, and the middle base has the indicator mounted on the post. Wire connections are established from the junction boxes to the indicator and sealed with liquid tight fittings.