



OEM Manual

MODEL 2353™ ELECTRONIC
MULTI - CYLINDER SCALE

Scaletron™ Industries, Ltd.
Bedminster Industrial Park
53 Apple Tree Lane
P.O. Box 365
Plumsteadville, PA 18949 USA

Toll Free: 1-800-257-5911 (USA & Canada)
Phone: (+1) 215-766-2670 (international)
Fax: (+1) 215-766-2672
E-mail: info@scaletronscales.com
Website: www.scaletronscales.com

These instructions generally describe the installation, operation, and maintenance of subject equipment. The manufacturer reserves the right to make engineering refinements that have not been described herein. Should any questions arise that may not be answered specifically by these instructions, they should be directed to **SCALETRON INDUSTRIES, LTD. OR OUR SALES AGENT** for a response.

All possible precautions were taken in packaging each piece of equipment to prevent shipping damage. Carefully inspect each item and report damages immediately. Report damage claims to shipping agent involved for equipment shipped F.O.B. job site. Do not install any damaged equipment.

All instructions given on any labels, or attached tags, should be followed. Carefully inspect all packing material before discarding to prevent the loss of accessories, mounting hardware, spare parts, or instructions.

TABLE OF CONTENTS		PAGE
I.	GENERAL DESCRIPTION.....	1
II.	SPECIFICATIONS.....	1
III.	ASSEMBLY AND START-UP INSTRUCTIONS.....	2
IV.	GENERAL USE INSTRUCTIONS.....	3
V.	CALIBRATION PROCEDURE.....	3
VI.	TROUBLESHOOTING.....	4
VII.	BOARD DIAGRAM AND CONNECTION DIAGRAMS.....	5 - 8

I. General Description

The Model 2353™ Digital Multi Cylinder Scale is designed for weighing cylinders 11 ¾ inches in diameter and smaller with a maximum net weight of 450 lbs. and a maximum tare weight of 450 lbs. The low profile design of the platform (1 ½ ") allows for safe and easy loading of cylinders. A pedestal, crossbar, and chains are provided to secure cylinders in place. The printed circuit board contains a power supply section and two separate tare and span controls, one for each set of discs. A 4-20 mA output signal is provided for each display. The weigh meter electronics are housed in a NEMA 4X enclosure for mounting on top of the pedestal, or remotely.

STANDARD PARTS

3 Base Assemblies
 3 Pedestals
 3 Crossbars
 1 Power cord
 3 Bags of Hardware
 1 Technical Manual
 6 Chains
 3 "U" Bolts
 1 Weigh meter to mount on center pedestal
 2 Remote boxes mount on left and right pedestal

AVAILABLE OPTIONS

A. Remote mounting of standard enclosure
 B. Load Cell Cable
 C. Low Level relay contact

II. Specifications

Display: LCD 3 ½ digit with minus sign, liquid crystal display, 0.5" high, seven segment

Resolution: Three cylinders 450 lbs. x 0.1 lbs. (204 kgs. x 0.1 kg.)

Load Cell Excitation: 12 VDC Power 18 Cells

Zero Adjustment: Internal potentiometer, external tare knobs

Overload: Blanks with "1" displayed at far left of display

Accuracy: +/- 0.5% capacity

Power: 85-265 VAC 50/60 Hz single phase, 0.42 Amps. DEDICATED-ISOLATED POWER WITH EARTH GROUNDING

Dimensions: Standard unit 32"W x 17.5"D x 58.75"H (Each Base)

III. Assembly and Start-up instructions

The Model 2353™ Digital Multi Cylinder Scale is shipped disassembled. Assembly instructions are as follows:

The load cells are secured to discs and mounted in the base housing. All wire connections in the base have been made and sealed at the factory. ***The digital weigh meter is assembled and calibrated to the base at the factory.*** The customer must mount the pedestals, crossbars and chains, indicators, and reconnect wires to the printed circuit board before scale can be operated.

Step 1: Remove all parts from box and inspect for damage – bent metal, broken wires, cracks in indicator, etc. Any shipping damage must be reported **to carrier!**

Step 2: Place the scale bases on a solid, dry, and even surface. Clear the area of all debris where the scale bases will be anchored.

Step 3: Secure the cross bars to the posts using the U-bolts and acorn nuts; make sure they are tightened enough to safely restrain the cylinder. Fasten the chain to cross bar with two "S" hooks in the holes provided. The cross bars should be at the proper height to restrain the size cylinder being used.

Step 4: Drill two, ½" holes in the indicator to allow for the wires from the left and right base remote box to enter. **CAUTION:** When drilling holes, please be sure not to hit the p.c. board or wires inside the box. Open the weigh meter (indicator) and install the black liquid tight fittings in the ½" holes drilled for the two remote boxes, and the ½" hole near the post bolt holes for the center base. Install the same fittings into the remote boxes that will mount on the left and right base pedestals. Feed the wire up through the fitting and snug the fitting on the wire. Fasten the indicator to the center base's pedestal. Insert the wires into the terminal blocks. The Center base will share a right disk with the Right base connections, and the Left base with the Center base, left disk connections.

Terminal block mounted to left side in back of indicator makes the connections for the left base and the center bases' left disk. The order of colors depends on the connections made at the factory. Please match up the corresponding colors into the empty side of the terminal block.

The code is as follows, putting the following colors together into the terminal block:

Black and Brown. Orange and Red. Yellow and White. Green and Blue. (Only one shield wire is present for the last connection, and it comes from the remote box. Attach this wire in the terminal block across from the black colored wire with the bright yellow sticker that says SHIELD.) They should match to the similar color whose wire is connected to the connector on the PC board. The Right side terminal has only matching color wires running into the terminal block. Green and Green, White and White, Black and Black. Red and Red. The shield wire is, again, only coming from the right side base. Place it in the connection directly across from the wire with the bright yellow shield sticker attached. These will be mounted directly across from their corresponding color wire that was connected at the factory. From the terminal blocks, there are factory installed wires that are connected as follows:

TB1 – 1: Common, 4-20mA Return*=Ret (right and center-right disk)

TB1 – 2: + 4-20mA Output* = Out (right and center-right disk)

TB1 – 3: Green (from right terminal block for right and center-right disk)

TB1 – 4: White (from right terminal block for right and center-right disk)

TB1 – 5: Black (from right terminal block for right and center-right disk)

TB1 – 6: Red (from right terminal block for right and center-right disk)

TB1 - 7: Black (from left terminal block for left and center-left disk)

TB1- 8: Red (from left terminal block for left and center-left disk)

TB1- 9: Green (from left terminal block for left and center-left disk)

TB1-10: White (from left terminal block for left and center-left disk)

TB1-11: Common, 4-20mA Return*= Ret (left and center-left disk)

TB1-12: +4-20mA Output*= Out (left and center-left disk)

*Connect your wires here if you are using 4-20mA output. Refer to the wiring diagram on page 5 and 6 for 4-20mA connections. Jumper J-4 will need jumper in the top two pins for loop powered, and the bottom two pins for scale powered (with board oriented as in drawing pg 5.)

IMPORTANT: Wires from the Right base and the right disk on the center base will connect by the wires located in connections 3 – 6 with the 4-20mA connection in #'s 1 & 2. The wires from the Left base and center base, left disk, will connect by the wires located in the connections labeled 7 – 10 with the 4-20 mA connection in 11 & 12.

Step 5: Allow approximately 15 minutes warm up time before using the scale

IV. General Use Instructions:

There are two separate ways to use this scale. **If you know the tare weight (the weight of the empty cylinder) please use the following procedure:**

Begin by allowing 15 minutes of warm up time for the first time use of the scale. With the base empty, add together the tare weight of the cylinder, plus the weight of any equipment that will mount on the cylinder, affecting the weight on the scale, and total that number. This is your total tare weight. With the scale empty, turn the black tare knob mounted on the outside of the door of the indicator, and turn it counter-clockwise to read a negative number that is the tare weight. (For instance, the tare weight is 300 lbs. total. You turn the black tare knob until the scale indicator reads “-300” lb.) Now you may load the full cylinders onto the disks and attach any equipment. Your display will read the NET WEIGHT (the weight of the contents only). As you use the contents, the weight will constantly read the net weight. When you are ready to refill, simply remove the used cylinders, adjust the tare weight to read the negative tare weight of the new cylinders and equipment, and load it onto the scale. You are then seeing the Net Weight again.

If you know the net weight of the cylinder (contents weight only), please use this procedure:

With the scale empty, determine the NET WEIGHT of the cylinders you are loading onto the scale. Load the cylinders onto the bases and hook up any equipment that may affect the weight reading of the scale. Using the black tare knob, under the display you are adjusting, on the outside of the indicator box, turn the black knob counter-clockwise until you see the (positive) number that is the net weight (contents). Doing this, you have “tared out” the cylinder weight and equipment weight so that the weight you see is the contents only. As you use the contents, the weight will constantly decrease until it is empty, and it is time to load a new cylinder. Load on the new cylinder, attach all equipment, and adjust the tare knob to read the known Net Weight again. You are ready to use the contents again.

V. Calibration Procedure

The Model 2353™ Multi Cylinder Scale is calibrated at the factory to within specified accuracy and is calibrated to standards traceable to the Bureau of Weights and Measures. No further calibration is necessary. If the electronics or load cells in base are replaced, the following calibration procedure should be used.

Steps are as follows:

1. Plug the AC Cord into a well-grounded receptacle. There is no power on / off switch, so power is applied as soon as it is plugged in.
2. Allow approximately 15 minutes warm-up time before calibration.
3. While indicator is warming up, proceed to check under cylinder support disc to make sure there is no debris.

Begin with one side of the scale to complete this process, and then return to step four to repeat on other side.

4. WITH NO WEIGHT APPLIED TO THE SCALE, turn the black tare knob on the outside of the door of the indicator in the clockwise direction to make sure that there is *at least* +10 lb. of weight in the tare knob. If not, adjust R-6 to see a positive reading. Once that is established, turn the black tare knob on the door of the indicator counter-clockwise until it stops (DO NOT OVER TURN KNOB OR YOU WILL DAMAGE THE TARE POT!) Once it reaches the most negative reading, make sure you have at least –450 lb. on the display.
5. Adjust tare knob on front of weigh meter until scale reads zero with no weight on platform. Adjust R-22 to set the 4mA reading to 0lbs.
6. Place known weights on the discs for that display (side base and one disk of center base), as close to center as possible. The calibration weight for this display should be equal to ½ of capacity, or greater.
7. Adjust R-15 until display reads weight of test weight on scale disc.
8. To complete calibration of 4-20mA output, adjust R-19 for proper 20 mA adjustment reading. Factory setting is for 20 mA at 450 lb (204 kg.) unless specified otherwise.
9. Calibration is complete if specified accuracy is obtained. **Repeat for second half of scale.**

VI. Troubleshooting

1. If Display reads “-1”:

- A. Gross under load, turn tare knob clockwise. Numbers should reappear and can be adjusted to tare weight or zero as required.
- B. Check load cell connections at indicator and connect wires per chart on page 2

2. If Display reads “1”:

- A. Gross overload, if starting point was zero, the cylinder weight is more than 1999 lbs., or kg. This is unlikely because the base is not rated to withstand this amount of weight. Gross weight should not exceed 900 lbs. for the combined disks.
- B. Check load cell connections according to page 2, Step 4

3. If No Display:

- A. Check power to weigh meter.
- B. Check green light on power supply board. It should be lit. If not lit, it is shorted out.

4. Other problems: (PLEASE HAVE SERIAL NUMBER OF SCALE WHEN CALLING)

- A. Consult factory:

**USA & Canada Toll-Free: (800) 257-5911
Tel: (+1) 215-766-2670 ♦ Fax: (+1) 215-766-2672**

Notice: Do not return any equipment without first contacting the factory. A return authorization number will be issued and it must be marked on all materials returned to the factory, accompanying a letter that explains the problem specifically. A Serial Number will also be required. It is located inside the indicator box.

VII. Board Diagram:

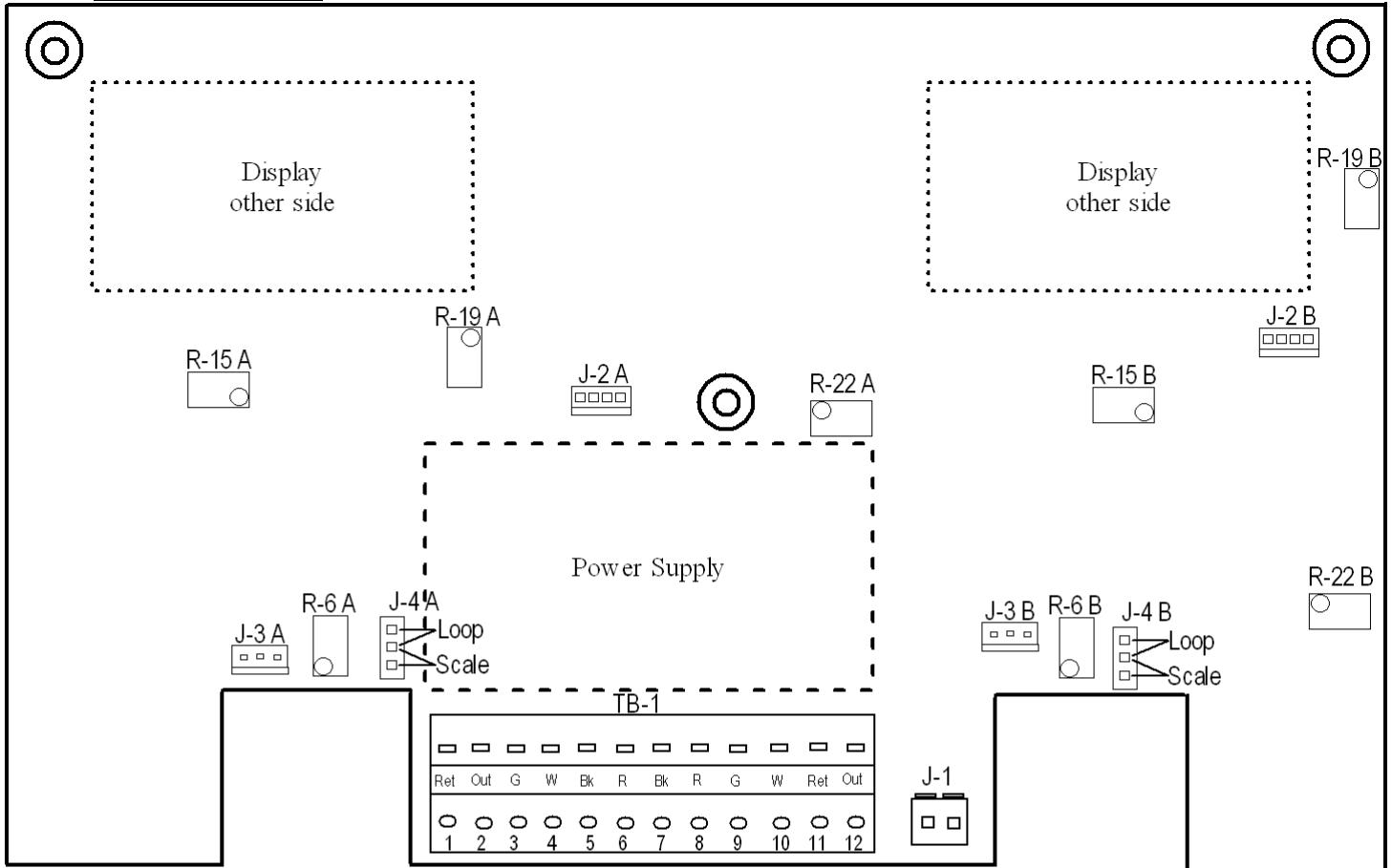

Ret = 4-20 mA Return
 Out = 4-20 mA Output
 G = Green = + Signal
 W = White = - Signal
 Bk = Black = - Supply
 R = Red = + Supply

Wires from right base and center base, right disk to right side terminal block, and into the connector in these locations

Wires from left base and center base, left disk together in connector

Bk = Black = - Supply
 R = Red = + Supply
 G = Green = + Signal
 W = White = - Signal

Ret = 4-20 mA Return
 Out = 4-20 mA Output

J-1 = AC Power Connection
 J-2 A & B = Low Level (optional) Connection
 J-3 A & B = Tare Pot Connection
 J-4 A & B = Scale or Loop Powered 4-20mA selection:
 Jumper on top two pins = Loop powered, Jumper on bottom two pins = Scale powered

R-6 A & B = Tare Span Adjustment
 R-15 A & B = Weight Span Adjustment
 R-19 A & B = 20 mA Adjustment
 R-22 A & B = 4 mA Adjustment

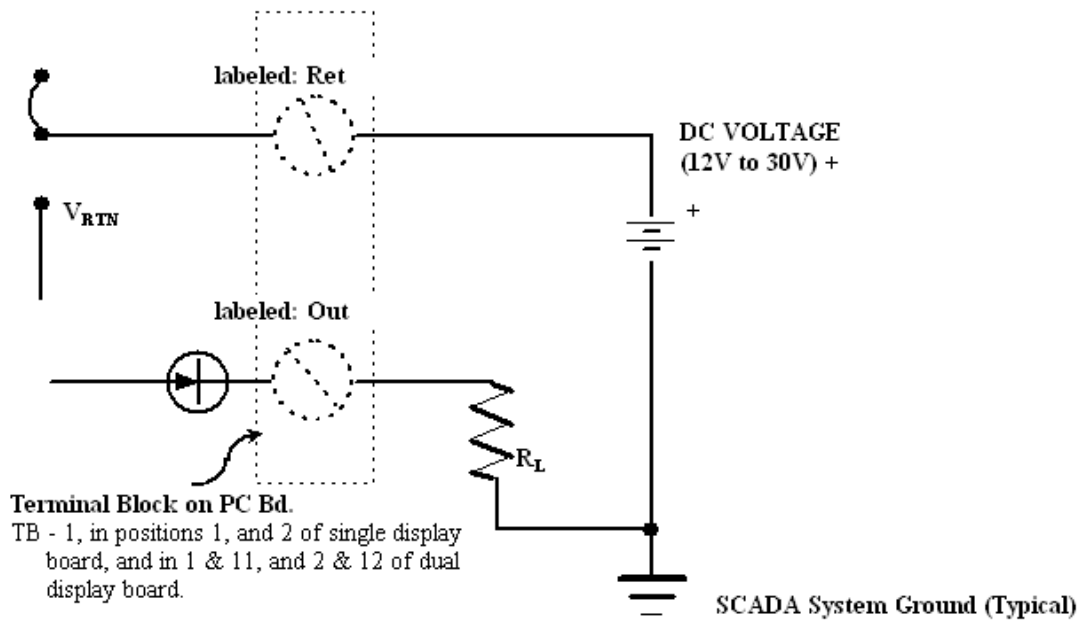
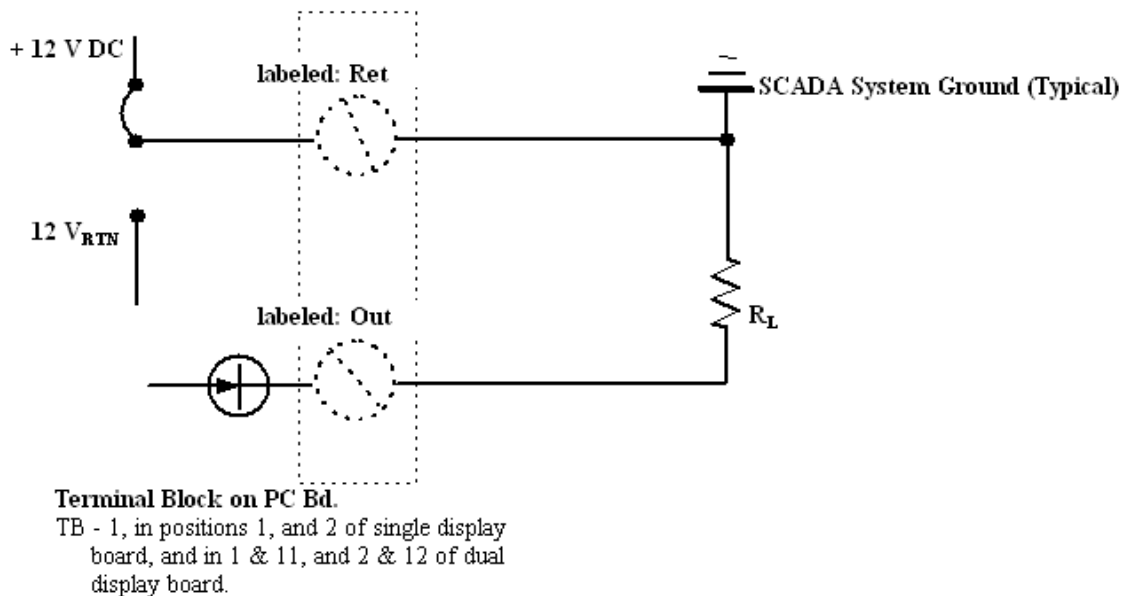
4-20mA Diagram:*Refer to appropriate diagram:***LOOP POWERED DIAGRAM****SCALE POWERED DIAGRAM**

Model 2353™

Indicator on post of middle scale
view of P.C.Board only

Remote Box Mounted on Post

Wires to middle scale

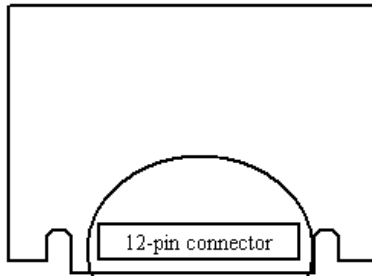

Wires to middle scale

Remote Box Mounted on Post

Wires from base

Wires from base

Please Note that there will be one wire from remote box, and one from center base in connector pins #3 to 10.

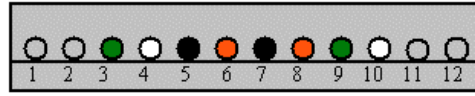

Wires to Right Base and Right disk on Center base

Wires to Left Base and Left disk on Center base

Special Instructions:
Wiring from Left base TO remote box:
Black and Brown TO #7 Black
Red and Orange TO #8 Red
White and Yellow TO #9 White
Green and Blue TO #10 Green

Wiring from center base is as follows:
#s 3-6 from remote and right base
3= Green and Green
4= White and White
5= Black and Black
6= Red and Red
#s 7-10 from remote and left base
7= Black and Brown
8= Red and Orange
9= Green and Blue
10= White and Yellow

Special Instructions:
Wiring from Right base TO remote box:
Blue and Green TO #3 Green
Yellow and White TO #4 White
Brown and Black TO #5 Black
Red and Orange TO #6 Red

**** Shield wires need to be tied down in the back of the indicator box where the tag indicates, using screw provided.**

**2353TM Junction Box
(Remote Box) Wiring
Orientation Diagram #2**

