



OEM Manual

MODEL 2308™
3 ½ Digit Electronic
Gas Cabinet Scale

These instructions generally describe the installation, operation, and maintenance of subject equipment. The manufacturer reserves the right to make engineering refinements that have not been described herein. Should any questions arise that may not be answered specifically by these instructions, they should be directed to **Scaleton Industries Ltd., Or Our Sales Agent** for a response.

All possible precautions were taken in packaging each piece of equipment to prevent shipping damage. Carefully inspect each item and report damages immediately. Report all damage claims to the shipping agent involved for equipment shipped F.O.B. job site. Do not install any damaged equipment.

All instructions given on any labels, or attached tags, should be followed. Carefully inspect all packing material before discarding to prevent the loss of accessories, mounting hardware, spare parts, or instructions.

TABLE OF CONTENTS	PAGE
I. GENERAL DESCRIPTION.....	1
II. SPECIFICATIONS.....	1-2
III. ASSEMBLY AND START-UP.....	2
IV. GENERAL USE INSTRUCTIONS.....	2-3
V. CALIBRATION PROCEEDURE.....	3
VI. TROUBLESHOOTING.....	3- 4
VII. BOARD DIAGRAM & 4-20mA CONNECTION DIAGRAM.....	5 - 6

I. **General Description:**

The Model 2308™ Digital Gas Cabinet Scale is designed for weighing cylinders 9 inches in diameter and smaller, with a maximum net weight of 199.9 lb. and a maximum tare weight of 150 lb. The low profile design of the platform allows for safe and easy loading and unloading of cylinders. The printed circuit board contains a power supply section and a separate tare and span control. The weigh meter electronics are housed in a NEMA 4X enclosure for mounting on wall.

Standard Parts

1 Base assembly	1 Weigh Meter (indicator)
1 Power Cord	1 Technical Manual

Available Options

- A. Remote mounting of standard enclosure
- B. Load Cell Cable
- C. Low Level relay contact

II. Specifications:

Display: LCD, 3 ½ Digit with minus sign liquid crystal display, 0.5 inch high, seven segment

Resolution: Single cylinder 199.9 lb x 0.1 lb, or 90.7 kg. x 0.1 kg.

Load Cell Excitation: 12 VDC Power, 4 Load cells

Zero Adjustment: Internal potentiometer, External tare knob

Overload: Blanks with “1” displayed at the far left of the display

Accuracy: +/- 0.5% full capacity

Power: 85-265VAC ~ 50/60 Hz, single phase, 0.3 Amps Dedicated – Isolated Power With Earth Grounding

Dimensions: Standard unit: 9 inches x 9 inches

III. Assembly and Start-Up:

The Model 2308™ Digital Gas Cabinet Scale is shipped partially disassembled. Assembly instructions are as follows:

The load cells are secured and mounted in the base housing. All wire connections in the base have been made and sealed at the factory. The digital weigh meter is assembled and calibrated to the base at the factory. The customer must mount the indicator on the wall. The wires must be run through the strain relief, connected to the connector, and plugged into indicator before scale is operated. Steps are as follows:

Step 1: Remove all parts from box and inspect for damage – bent metal, broken wires, cracks in indicator, etc. Any shipping damage must be reported **to carrier!**

Step 2: Place the scale on a solid, dry, and even surface. Clear the area of all debris where the scale base will be placed.

Step 3: Open the weigh meter (indicator) and install one black liquid tight fitting in the hole. Feed the wire up through the fitting and snug the fitting on the wire. Fasten the indicator to the wall. Connect the wires into the connector using the following code:

TB1 : **Ret:** Common, 4-20mA Return*

Out: + 4-20mA Output*

W: White = - Signal

R: Red = + Supply Voltage

Bk: Black = - Supply Voltage

G: Green = + Signal

*Connect your wires here if you are using 4-20mA output. Refer to the wiring diagram on page 5 and 6 for 4-20mA connections. Jumper J-4 will need jumper in the top two pins for loop powered, and the bottom two pins for scale powered (with board oriented as in drawing pg 5.)

Insert the wire, being sure not to crimp the insulation in the connector. Using a small screwdriver, push the orange lever down to insert the wire into the proper hole and release the lever to allow the wire to clamp into the connector. The connector holes are labeled according to the color that is inserted there.

Step 4: Allow approximately 15 minutes warm up time before using the scale.

IV. General Use Instructions:

Please refer to these instructions for daily use of this scale. These instructions simulate the procedure for every day usage.

To load a new, full cylinder, please follow these steps:

1. If you know what the **Tare Weight** of your cylinder (the weight of an empty cylinder) you may turn your black tare knob (located on the front of the indicator door) counterclockwise, until the tare weight is shown on the LCD indicator as a negative number. *(Ex: Your cylinder is stamped with a tare weight of 100 lbs. You turn your tare knob counterclockwise until it reads “-100”. Then you load the cylinder on to the base.)*

Do not load the cylinder on before you have reached the tare weight.

-OR-

2. If you do not know the tare weight of the cylinder, or if you DO know the **Net Weight**, (the weight of the contents of the cylinder) you may use this alternate procedure. Load the full cylinder on to the scale base. Turn the tare knob, located on the door of the indicator, counterclockwise, until the known weight of the contents is displayed on the LCD. *(Ex: You have a cylinder that holds 150 lbs. of contents. Load the cylinder on the scale and turn the black tare knob located on the front of the indicator door until the weight of the contents, 150 lb., is displayed on the LCD display. You are ready to start using the contents.)*

When cylinder is empty, remove old cylinder, and load new one using the instructions above.

V. Calibration Procedure:

The Model 2308™ Digital Gas Cabinet Scale is **pre-calibrated at the factory to within specified accuracy and is calibrated to standards traceable to the Bureau of Weights and Measures. No further calibration should be necessary. If the electronics or load cells in the base are being replaced, the following procedure should be used.**

1. Plug the AC Cord into a well-grounded receptacle. There is no power on / off switch, so power is applied as soon as it is plugged in.
2. Allow approximately 15 minutes warm-up time before calibration.
3. WITH NO WEIGHT APPLIED TO THE SCALE, turn the black tare knob on the outside of the door of the indicator in the clockwise direction to make sure that there is *at least* +10 lb. of weight in the tare knob. If not, adjust R-6 to see a positive reading. Once that is established, turn the black tare knob on the door of the indicator counter-clockwise until it stops (DO NOT OVER TURN KNOB OR YOU WILL DAMAGE THE TARE POT!) Once it reaches the most negative reading, make sure you have at least -150 lb. on the display. If the tare span is large, you may get to a -1 reading and this is a weight under-load condition. Turn R-6 until you see a number a number that is not “below” -199.9 lb.
4. Adjust tare knob on front of weigh meter until scale reads zero with no weight on platform. Adjust R-22 to set the 4mA reading to 0lbs.
5. Place a known weight on the base plate, as close to center as possible. Weight should be equal to ½ of capacity, or greater.
6. Adjust R-15 until display reads weight of test weight on scale disc.
7. To complete calibration of 4-20mA output, adjust R-19 for proper 20 mA adjustment reading. Factory setting is for 20 mA at 150.0 lb (68 kg.) unless specified otherwise.
8. Calibration is complete if specified accuracy is obtained.

VI. Troubleshooting:

1. If display reads: “-1”:

- A. Gross under-load. Turn knob clockwise. Numbers should reappear and can be adjusted to tare weight or zero as required.
- B. Check load cell connections at indicator, and connect wires as per diagram on Page 5.

2. If display reads: “1”:

- A. Gross over-load. If starting point was zero, the cylinder weight is more than 199.9 lb., or kg.
- B. If starting point was -150.0 lb. (68kg.) then the cylinder weight is more than 349.9 lb. (158 kg.). Remove weight and recheck tare setting.
- C. Check load cell connections according to page 2.

3. If no display (not lit):

- A. Check power to weigh meter.
- B. Check green light on power supply board. It should be lit. If not lit, it is shorted out.

4. Other Problems:

- A. Consult the Factory!

USA & Canada Toll-Free: (800) 257-5911

Tel: (+1) 215-766-2670 ♦ Fax: (+1) 215-766-2672

Notice: Do not return any equipment without first contacting the factory. A return authorization number will be issued and it must be marked on all materials returned to the factory, accompanying a letter that explains the problem specifically. A Serial Number will also be required. It is located inside the indicator box.

VII. Board Diagram:

3 1/2 digit LCD Board

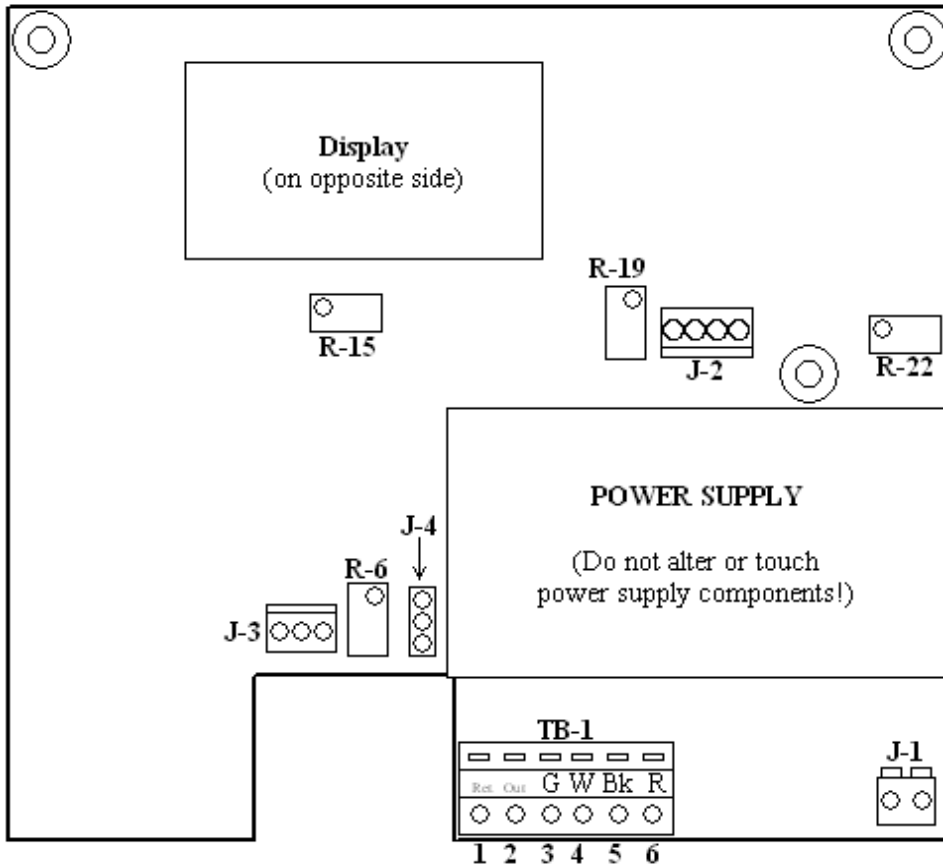

From left to right with P.C. Board as shown, the following connections should be made:
 (Connector is identified with positions 1-6 from left to right, but is not labeled on the p.c. board.)
 Sticker on connector identifies the color wires from the base to connect to TB-1.

TB-1:

- 1 - (Ret) Common, 4-20mA return
- 2 - (Out) + 4-20mA Output
- 3 - Green = G = + Signal
- 4 - White = W = - Signal
- 5 - Black = Bk = - Supply Voltage
- 6 - Red = R = + Supply Voltage

J-1 - Voltage (AC) line connection

J-2 - Optional Low Level Board connection

J-3 - Tare Pot connector

J-4 - Top two pins jumpered for Loop Powered 4-20mA,
 Bottom two pins jumpered for Scale Powered 4-20mA.

R-6 - tare adjustment

R-15 - weight span

R-19 - 20mA adjustment

R-22 - 4mA adjustment

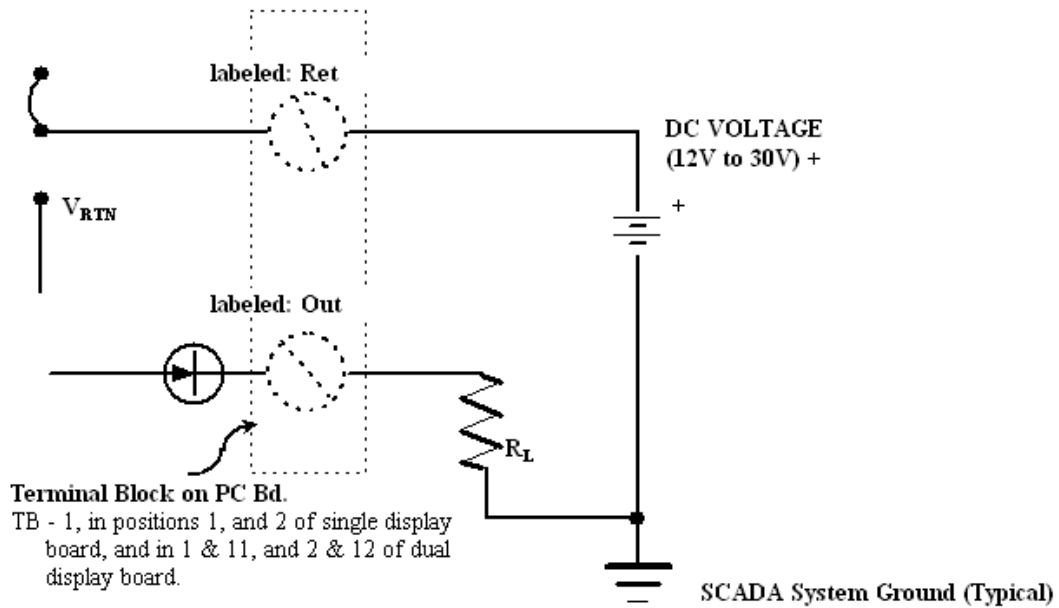
4-20mA Diagram:*Refer to appropriate diagram:***LOOP POWERED DIAGRAM****SCALE POWERED DIAGRAM**