



**Scaleton™
Sets The Standard
In Corrosion
Resistance**

Model 4021™ Ultra-Low Profile Drum Scale

- Designed for frequent on and off loading of carboys and drums
- Standard base sizes: 18" and 26"
- Gross capacity range: 0 - 1500 lbs. (680 kg)
- High accuracy of $\pm 0.1\%$ of capacity
- Standard indicator: 3-1/2 digit LCD display with easy readability to 1 lb. (kg) or 0.1 lb. (kg)
- Readout in pounds or kilograms



3-1/2 Digit Indicator
(Standard)



4-1/2 Digit Indicator
(Optional)



1020 5 Digit
Controller (Optional)



1099 Chemical
Process Controller (Optional)



Standard Features

- Rugged steel construction protected by a corrosion resistant finish, with solid 1/2" PVC decking
- Ultra-low profile platform design increases safety and ease of drum handling
- Heavy-duty steel backstop to help center the drum
- Electronic indicator housed in NEMA 4X, UL approved enclosure to provide protection from acids
- NTEP stainless steel temperature compensated load cell
- Self-locking tare adjustment knob
- 4-20 mA output signal – scale or loop powered
- 20 ft. of 4 conductor wire cable

Options

- 240 VAC power (4-1/2 digit display)
- 4-1/2 digit display with active and passive 4-20 mA, 0-20 mA, and -8 to +12 mA, and two adjustable low level contacts
- Model 1020™ 5 digit controller with loop powered 4-20 mA, up to four adjustable set points and one or two channels
- Model 1099™ Chemical Process Controller
- Remote mounting of indicator box up to 200 feet (61 meters) away
- Junction box – Additional length of wire cable

Chemicals

Scale is designed to accurately measure weight of alum, ammonia, caustic, fluoride, phosphate, polymers, sodium aluminate, sodium bisulfate, sodium hydroxide, sodium hypochlorite and other liquids or powders

Scaleton Industries Ltd.

Bedminster Industrial Park
53 Apple Tree Lane • P.O. Box 365
Plumsteadville, PA 18949 • USA

Tel: (+1) 215-766-2670 (International)
Tel: (+1) 800-257-5911 (USA & Canada)
Fax: (+1) 215-766-2672

Email: info@scaletonscales.com
Website: www.scaletonscales.com

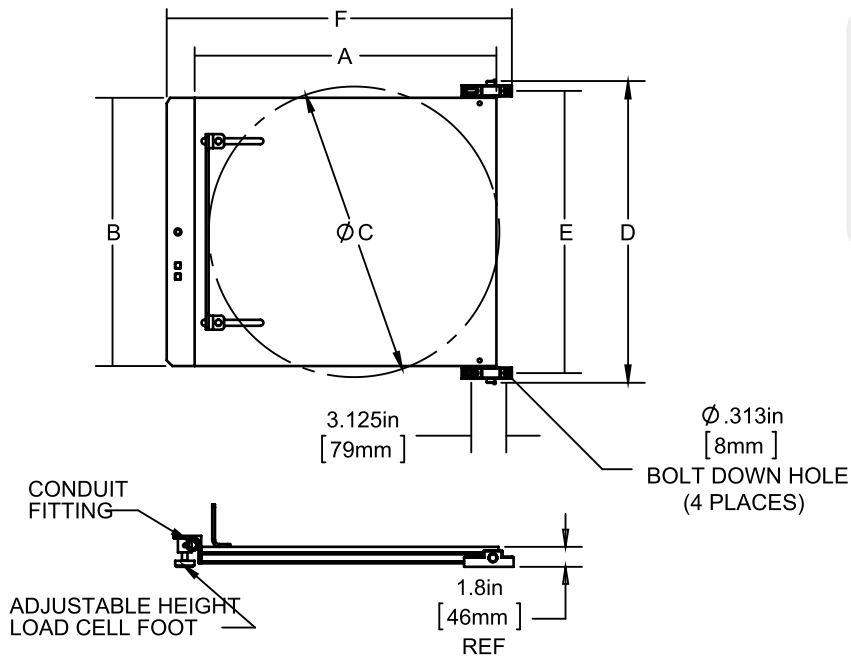

Model 4021™ Ultra-Low Profile Drum Scale General Specifications

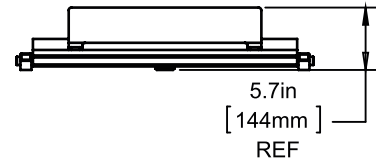

Indicator:	3-1/2 Digit	4-1/2 Digit	1020™	1099™ C.P.C.
Platform Size:	Adjustable – 4021-18 accommodates cylinders from 10" to 18" diameter (254 mm to 456.9 mm) Adjustable – 4021-26 accommodates cylinders from 18" to 26" diameter (456.9 mm to 659.9 mm)			
Platform Height:	1-3/4" high (44.5 mm)			
Gross Capacity:	4021-18: up to 1000 lbs. (453.6 kg); 4021-26: up to 1500 lbs. (680.4 kg) (150% overload protection is provided)			
Accuracy:	0.5% of full capacity		0.1% - 0.25% full capacity	
Resolution:	0.1 up to 199.9, or 1.0 over 200 lbs. (kg)		0.1 up to 999.9, or 1.0 over 1000 lbs. (kg)	
4-20 mA:	Standard – scale or loop powered		Standard on Channel 1, Optional on Channel 2 – loop powered	Standard on Channel 1 – loop powered (available for Channels 2 thru 4)
Level Indication/ Relay Contacts:	Optional	(2) Standard	Optional – Up to 4 (as high or low) on one channel or more than one per channel for a total of 4 set points with relay contract	
Power:	85 VAC to 265 VAC	120VAC, 50/60 Hz, 0.3A 240VAC, 50/60Hz, 0.15A	85VAC to 265VAC	
Enclosure:	NEMA 4X, UL Approved Enclosure			
Shipping Weight:	4021-18 = 80 lbs.; 4021-26 = 110 lbs.			

Typical Specifications

The Ultra-Low Profile Drum/Cylinder Scale must have rugged steel frame that is zinc oxide primed and dry powder epoxy coated. Decking shall be solid PVC. All hardware shall be stainless steel to prevent corrosion. There must be a provision for securing weigh frame to floor. The profile shall not exceed 1.75 inches (45mm) so as not to require a pit or ramp. The load cell must be NTEP approved, stainless steel shear beam cell. Drums and cylinders shall be centered and placed against heavy duty backstop. Base must be fully electronic with no mechanical lever system to corrode.

Scale shall be a Model 4021™ as manufactured by Scaleton Industries Ltd., Plumsteadville, PA.

**5 year FULL warranty
on ALL products!**

STANDARD INDICATOR:

3-1/2 Digit LCD Indicator: Indicator must be electronic with digital display with characters 0.5 inches high, with 0.1 lb. or 0.1 kg resolution and housed in a NEMA 4X, UL approved enclosure. Indicator is required to have 4-20 mA output selectable as scale powered or loop powered, standard. Indicator must have a knob to set tare weight. Accuracy is 0.5% of full scale, or better.

OPTIONAL INDICATORS/CONTROLLERS:

4-1/2 Digit LED indicator: Indicator must be electronic with digital display with characters 0.56 inches high and housed in a NEMA 4X, UL approved enclosure. An output of 4-20 mA, 0-20 mA, or -8 to + 12 mA, selectable as scale or loop powered to provide versatility to interface with related equipment, must be standard equipment. Indicator comes with two low level relay contacts, standard. A knob to set tare weights is required. Indicator must be capable of 0.1 lb. or 0.1 kg up to 1000.0 lbs. or kg. Accuracy is 0.5% of full scale, or better.

Model 1020™ 5 Digit Controller: Controller must be electronic with a two line, backlit alphanumeric digital display and housed in a NEMA 4X, UL approved enclosure. Available as single or dual channel and capable of displaying two channels simultaneously. A loop powered programmable output of 4-20 mA and four set points per channel must be standard equipment. Indicator must be capable of 0.1 lb. or 0.1 kg up to 1500 lbs. or 680.4 kg. Accuracy is 0.25% of full scale, or better.

Model 1099™ Chemical Process Controller see separate specification.