



OEM Manual

MODEL 4021™ 3½ DIGIT
ULTRA LOW PROFILE SCALE

Scaletron™ Industries, Ltd.
Bedminster Industrial Park
53 Apple Tree Lane
P.O. Box 365
Plumsteadville, PA 18949 USA

Toll Free: 1-800-257-5911 (USA & Canada)
Phone: (+1) 215-766-2670 (international)
Fax: (+1) 215-766-2672
E-mail: info@scaletronscales.com
Website: www.scaletronscales.com

These instructions generally describe the installation, operation, and maintenance of subject equipment. The manufacturer reserves the right to make engineering refinements that have not been described herein. Should any questions arise that may not be answered specifically by these instructions, they should be directed to **Scaleton Industries Ltd., Or Our Sales Agent** for a response.

All possible precautions were taken in packaging each piece of equipment to prevent shipping damage. Carefully inspect each item and report damages immediately. Report all damage claims to the shipping agent involved for equipment shipped F.O.B. job site. Do not install any damaged equipment.

All instructions given on any labels, or attached tags, should be followed. Carefully inspect all packing material before discarding to prevent the loss of accessories, mounting hardware, spare parts, or instructions.

TABLE OF CONTENTS	PAGE
I. GENERAL DESCRIPTION.....	1
II. SPECIFICATIONS.....	2
III. ASSEMBLY AND START-UP.....	2 - 3
IV. GENERAL USE INSTRUCTIONS.....	3
V. CALIBRATION PROCEEDURE.....	4
VI. TROUBLESHOOTING.....	4 - 5
VII. BOARD DIAGRAM.....	6 - 7

I. **General Description:**

The Model 4021™ Ultra Low Profile Platform Scale is available with two platform sizes. The 18" platform will accommodate cylinders sized from 10" diameter to 18" diameter, and the 26" platform will accommodate cylinders sized from 18" diameter up to 26" diameter. The maximum reading is 199.9 lb./ or kg at 0.1 lb/ or kg resolution. For the Model 4021™-18", the maximum reading is 1000 lb (394 kg) at 1.0 lb/kg resolution, and the Model 4021™-26" has a maximum reading of 1500 lb (591 kg) at 1.0 lb/kg resolution. If maximum net weight is over 199.9, the decimal is blanked at the factory, and the display can read 1999 lb/ or kg., but the maximum weight reading on the base is 1000 lb. for the 18, and 1500 lb. for the 26", and this **should not** be exceeded.

The low profile design of the platform (1 ½ inches) allows for safe and easy loading and unloading of cylinders. A crossbar and chain are provided to secure cylinders in place. The printed circuit board contains a power supply section and a separate tare and span control. The weigh meter electronics are housed in a NEMA 4X enclosure for mounting on wall.

Standard Parts

- 1- Base assembly
- 1- Weigh Meter (indicator)
- 1- Power Cord
- 1- Technical Manual

Available Options

- A. Remote mounting of standard enclosure
- B. Load Cell Cable
- C. Low Level relay contact

II. Specifications:

Display: 3 ½ Digit LCD with minus sign liquid crystal display, 0.5" high, seven segment

Resolution: 199.9 lbs./kg. X 0.1 lbs./kg., 600 lbs./(272 kg.) X 1 lbs./kg.

Load Cell Excitation: 12 VDC Power 1 Cell

Zero Adjustment: Internal potentiometer, external tare knob

Overload: Blanks with "1" displayed at far left of display

Accuracy: +/- 0.5% Capacity

Power: 85 – 265 VDC, 50/60 Hz single phase, 0.42 Amps. DEDICATED - ISOLATED POWER WITH EARTH GROUNDING

Dimensions: 18" base: 18 "w x 20 "d x 1 ¾"h 26" base: 24"w x 27"d x 1 ¾"h

III. Assembly and Start-Up:

The Model 4021™ Ultra Low Profile Platform Scale is shipped partially disassembled.

Assembly instructions are as follows:

The load cell is secured to platform has been tested for clearance. **DO NOT LOOSEN AND MOVE CELL.** All wire connections in the base have been made and sealed at the factory.

The digital weigh meter is assembled and calibrated to the base at the factory. The customer must mount the indicator on the wall. The base must be anchored and secured to floor. The wires must be run through conduit (if used) and into the connector before scale is operated.

Steps are as follows:

Step 1: Remove all parts from box and inspect for damage – bent metal, broken wires, cracks in indicator, etc. Any shipping damage must be reported **to carrier!**

Step 2: Clear the area of all debris where the scale base will be anchored. Place the scale on a solid, dry, and even surface.

Step 3: Feed the wire through conduit (flexible conduit run horizontally for at least 2 feet is required if it is to attach to the base as to not interfere with the proper operation of the scale).

The wire will be fed into the indicator. Make sure that the proper size hole is drilled in the indicator for the conduit used, and any open areas of the box are sealed. This means if there is an open area around the conduit, you **must fill any void with silicon caulk, or other substance to prevent gas from attacking the electronics in the indicator!** Fasten the indicator to the wall. Connect the wires into the connector using the following code:

TB1 : Ret: Common, 4-20mA Return*

Out: + 4-20mA Output*

G: Green = + Signal

W: White = - Signal

Bk: Black = - Supply Voltage

R: Red = + Supply Voltage

*Connect your wires here if you are using 4-20mA output. Refer to the wiring diagram on page 5 and 6 for 4-20mA connections. Jumper J-4 will need jumper in the top two pins for loop powered, and the bottom two pins for scale powered (with board oriented as in drawing pg 5.)

Insert the wire, being sure not to crimp the insulation in the connector. Using a small screwdriver, push the orange lever down to insert the wire into the proper hole and release the lever to allow the wire to clamp into the connector. The connector holes are labeled according to the color that is inserted there.

Step 4: Allow approximately 15 minutes warm up time before using the scale.

Step 5: Make sure that the tank or drum is centered on the base when being placed. Adjust the back-stop to brace against proper position. Use the measuring scale on the base to adjust the backstop to proper drum / tank diameter.

IV. General Use Instructions:

Please refer to these instructions for daily use of this scale. These instructions simulate the procedure for every day usage.

****Be sure that back-stop is adjusted to the proper drum / cylinder diameter!!! This is crucial to accurate readings! ****

To load a new, full cylinder, please follow these steps:

1. If you know what the tare weight of your cylinder (the weight of an empty cylinder) you may turn your black tare knob (located on the front of the indicator door) counterclockwise, until the tare weight is shown on the LCD indicator as a negative number. *(Ex: Your cylinder is stamped with a tare weight of 100 lbs. You turn your tare knob counterclockwise until it reads “-100”. Then you load the cylinder on to the base, being sure that it is completely centered on the base.)*

Do not load the cylinder on before you have reached the tare weight.

-OR-

2. If you do not know the tare weight of the cylinder, or if you DO know the Net Weight, (the weight of the contents of the cylinder) you may use this alternate procedure. Load the full cylinder on to the scale base being sure that the cylinder does not sit on the base. When cylinder is centered, turn the tare knob (located on the door of the indicator) counterclockwise, until the known weight of the contents is displayed on the LCD. *(Ex: You have a cylinder that holds 150 lbs. of contents. Load the cylinder on the scale, and turn the black tare knob located on the front of the indicator door until the weight of the contents, 150 lb., is displayed on the LCD display. You are ready to start using the contents.)*

When cylinder is empty, remove chains, remove old cylinder, and load new one using the instructions above.

For use when FILLING the TANK instead of on & off loading:

To start with a new, EMPTY tank that will be filled while on the scale base, please follow these steps:

Load the new, empty tank on to the platform. Be sure to connect all equipment to the tank that may apply weight to the scale. With this weight applied, turn the black tare knob located on the outside, front of the indicator, until the digital reading says zero. This means that your digital reading will show net weight, or the weight of the contents alone. As you fill the tank, the scale shows the current weight. Do not readjust the tare weight unless you are starting with a dry, new, empty tank. Any residual weight will reflect what is left in the tank, and should not be changed unless a new tank is put on the base.

V. Calibration Procedure:

The Model 4021™ Ultra Low Profile Platform Scale is **pre-calibrated at the factory to within specified accuracy** and is calibrated to standards traceable to the Bureau of Weights and Measures. **No further calibration should be necessary. If the electronics or load cells in the base are being replaced, the following procedure should be used.**

1. Plug the AC Cord into a well-grounded receptacle. There is no power on / off switch, so power is applied as soon as it is plugged in.
2. Allow approximately 15 minutes warm-up time before calibration.

3. While indicator is warming up, proceed to check under cylinder support disc to make sure there is no debris.
4. WITH NO WEIGHT APPLIED TO THE SCALE, turn the black tare knob on the outside of the door of the indicator in the clockwise direction to make sure that there is *at least* +10 lb. of weight in the tare knob. If not, adjust R-6 to see a positive reading. Once that is established, turn the black tare knob on the door of the indicator counter-clockwise until it stops (DO NOT OVER TURN KNOB OR YOU WILL DAMAGE THE TARE POT!) Once it reaches the most negative reading, make sure you have enough tare weight for your tank/cylinder. This weight should not need adjusting since the factory requests this information at the time of the order and sets it.
5. Adjust tare knob on front of indicator until scale reads zero with no weight on platform. Adjust R-22 to set the 4mA reading to 0lbs.
6. Place a known weight on the platform so the center of the weight is the proper distance from the backstop. (If the backstop is set for an 18" container, the center of the container must be 9 inches from the backstop) Weight should be equal to ½ of capacity, or greater.
7. Adjust R-15 until display reads weight of test weight on scale disc.
8. To complete calibration of 4-20mA output, adjust R-19 for proper 20 mA adjustment reading. The factory requires a net weight at the time of order so that it may be set properly in the factory. Please use the same net weight that was given to us at the time of order. Please consult the white, "4-20mA settings" sticker inside the indicator for this weight.
9. Calibration is complete if specified accuracy is obtained.

VI. Troubleshooting:

1. If display reads: "-1":

- A. Gross under-load. Turn knob clockwise. Numbers should reappear and can be adjusted to tare weight or zero as required.
- B. Check load cell connections at indicator, and connect wires as per diagram on Page 5.

2. If display reads: "1":

- A. Gross over-load. If starting point was zero, the cylinder weight is more than 199.9 lb., or kg.
- B. If starting point was -150.0 lb. (68kg.) then the cylinder weight is more than 349.9 lb. (158 kg.). Remove weight and recheck tare setting.
- C. Check load cell connections according to page 2.

3. If no display (not lit):

- A. Check power to weigh meter.
- B. Check green light on power supply board. It should be lit. If not lit, it is shorted out.

4. Other Problems:

- A. Consult the Factory!

USA & Canada Toll-Free: (800) 257-5911
Tel: (+1) 215-766-2670 ♦ Fax: (+1) 215-766-2672

Notice: Do not return any equipment without first contacting the factory. A return authorization number will be issued and it must be marked on all materials returned to the factory, accompanying a letter that explains the problem specifically. A Serial Number will also be required. It is located inside the indicator box.

VII. BoardDiagram:

3 1/2 digit LCD Board

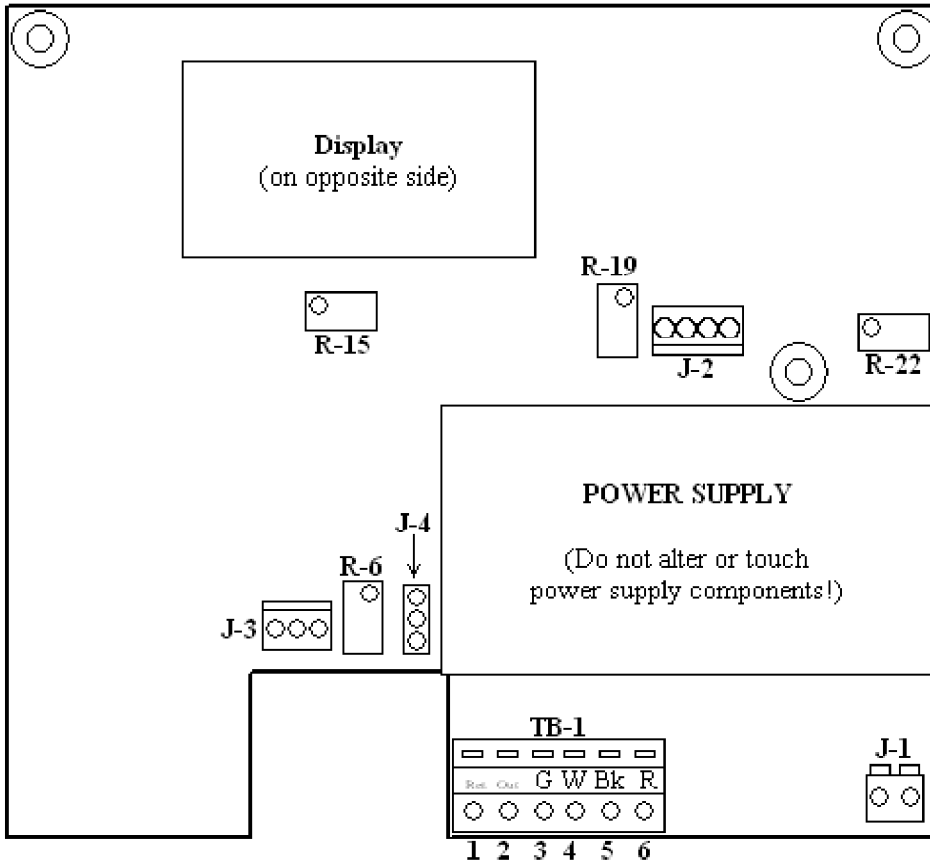

From left to right with P.C. Board as shown, the following connections should be made:
(Connector is identified with positions 1-6 from left to right, but is not labeled on the p.c. board.)
Sticker on connector identifies the color wires from the base to connect to TB-1.

TB-1:

- 1 - (Ret) Common, 4-20mA return
- 2 - (Out) + 4-20mA Output
- 3 - Green = G = + Signal
- 4 - White = W = - Signal
- 5 - Black = Bk = - Supply Voltage
- 6 - Red = R = + Supply Voltage

J-1 - Voltage (AC) line connection

J-2 - Optional Low Level Board connection

J-3 - Tare Pot connector

J-4 - Top two pins jumpered for Loop Powered 4-20mA,
Bottom two pins jumpered for Scale Powered 4-20mA.

R-6 - tare adjustment

R-15 - weight span

R-19 - 20mA adjustment

R-22 - 4mA adjustment

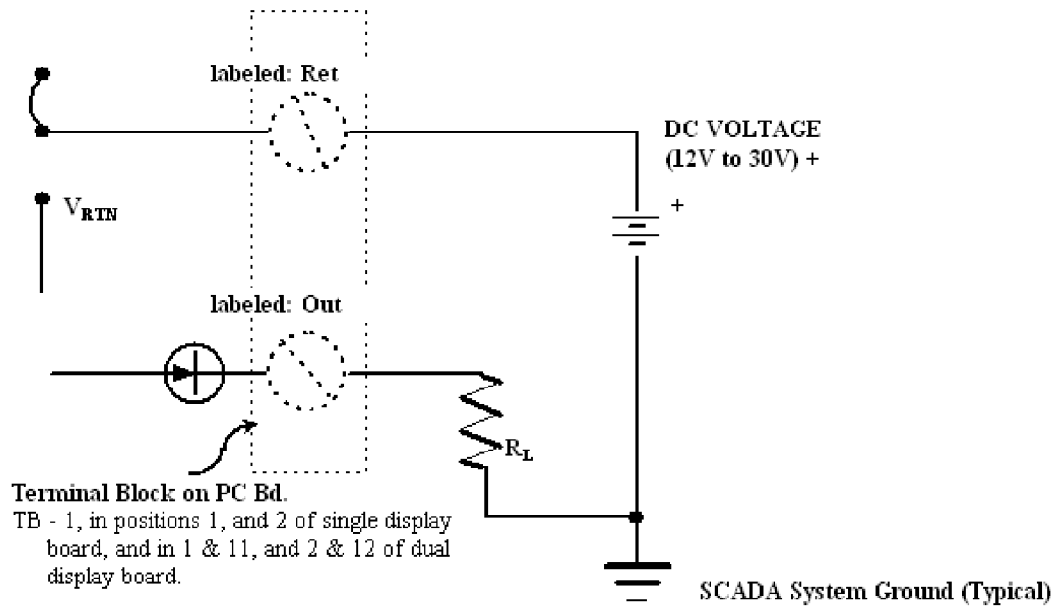
4-20mA Diagram:*Refer to appropriate diagram:***LOOP POWERED DIAGRAM****SCALE POWERED DIAGRAM**