

MODEL NUMBERS

VMF-90C

18" x 33.5" x 16.5"

Qty	Model No.

AVAILABLE OPTIONS:

1. LIFT-OFF LID
2. ELECTRIC VIBRATORY AGITATOR
3. MODULAR CARBON STEEL FEEDER STAND

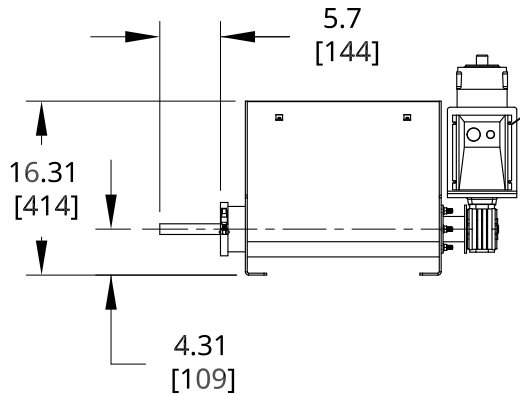
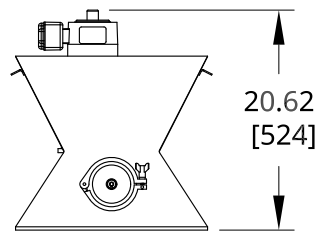
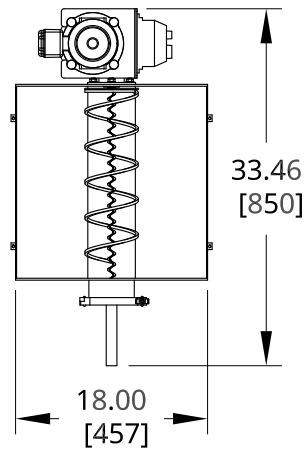

1/3 HP 1750 RPM
WASHGUARD™ MOTOR

CARBON STEEL FEEDER
CONSTRUCTION

0.75" DISCHARGE SCREW
WITH OVERWIND AUGER

VARIABLE SPEED
DC CONTROLLER

VMF-90C STANDARDS:

1. VOLUME OF VMF-90C IS 1.5 FT³
2. CARBON STEEL OR STAINLESS STEEL CONSTRUCTION
3. 0.75" OPEN HELIX SCREW WITH CONCENTRIC MATERIAL CONDITIONING AUGER
4. 115V/230V 1 PHASE 60 HZ 1/3 HP TENV 56 C FRAME 1750 RPM WASHGUARD™ MOTOR
5. 21:1 / 83 RPM GEAR RATIO
6. VARIABLE SPEED DC CONTROLLER



Bedminster Industrial Park
53 Apple Tree Lane P.O. Box 365
Plumsteadville, PA 18949 USA
www.scaletronscales.com
info@scaletronscales.com
Toll Free: 1-800-257-5911 (USA & Canada)
Phone: (+1) 215-766-2670 (International)
Fax: (+1) 215-766-2672

SCALETRON MODEL VMF-90C ECONOMICAL VOLUMETRIC SCREW FEEDER

DRAWN BY: KEH

DATE: 09/07/2018

SCALE: DO NOT SCALE

DRAWING NUMBER

MK19-U-04

REV 02