

MODEL NUMBERS

VMF-90D

18" x 33.5" x 16.5"

Qty	Model No.

AVAILABLE OPTIONS:

1. LIFT-OFF LID
2. EXPLOSION PROOF CLASSIFICATION
3. PROGRAMMABLE FEEDER CONTROL MODULE STAND
4. STAINLESS STEEL OR CARBON STEEL CONSTRUCTION FEEDER STAND
5. LIW SYSTEM "LOSS IN WEIGHT"

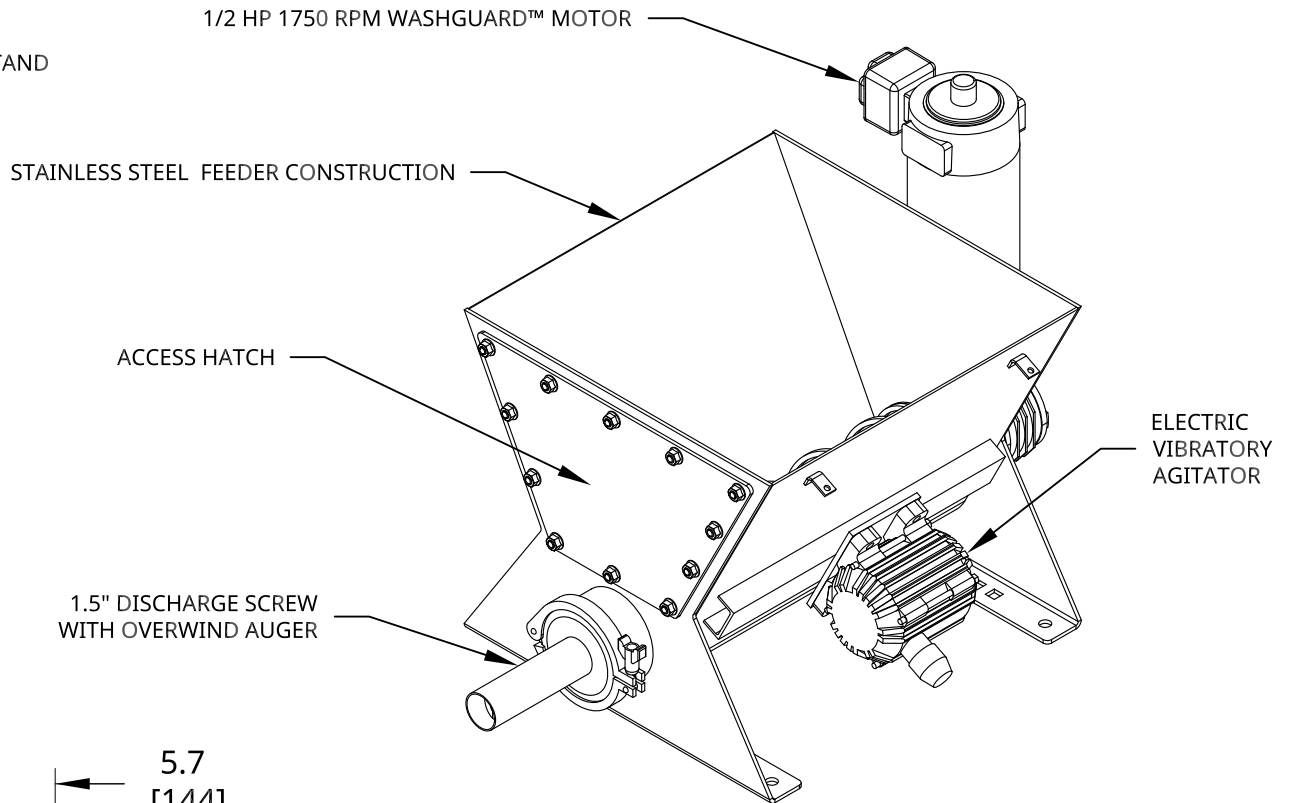
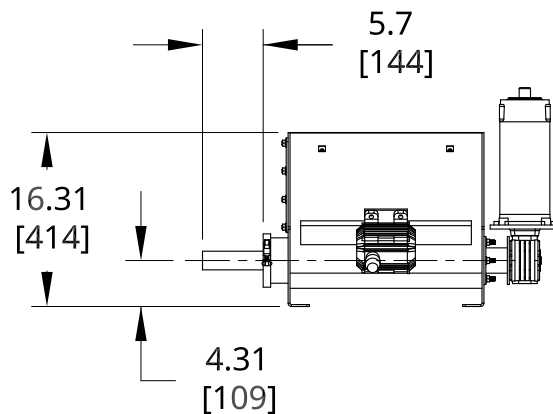
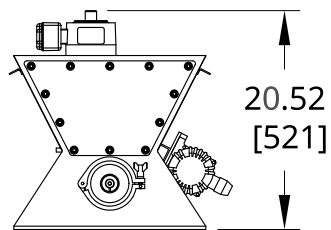
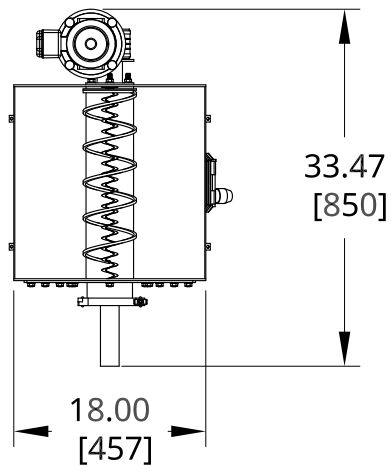

VMF-90D STANDARDS:

1. VOLUME OF VMF-90D IS 1.5 FT³
2. 304 STAINLESS STEEL CONSTRUCTION
3. 1.5" OPEN HELIX SCREW WITH CONCENTRIC MATERIAL CONDITIONING AUGER
4. 115V/230V 1 PHASE 60 HZ 1/2 HP TENV 56 C FRAME 1750 RPM WASHGUARD™ MOTOR
5. 28:1 GEAR RATIO / 63 RPM
6. ELECTRIC VIBRATORY AGITATOR
7. PROGRAMMABLE FEEDER CONTROL MODULE ENCLOSED IN NEMA 4X BOX



Bedminster Industrial Park
 53 Apple Tree Lane P.O. Box 365
 Plumsteadville, PA 18949 USA
 www.scaletroncales.com
 info@scaletroncales.com
 Toll Free: 1-800-257-5911 (USA & Canada)
 Phone: (+1) 215-766-2670 (International)
 Fax: (+1) 215-766-2672

SCALETRON MODEL VMF-90D
INDUSTRY STANDARD
VOLMETRIC SCREW FEEDER

DRAWN BY: KEH

DATE: 08/22/2018

SCALE: DO NOT SCALE

DRAWING NUMBER

MK19-U-03

REV 02