

MODEL NUMBERS

VMF-90F

48" x 31" x 51.5"

Qty	Model No.

AVAILABLE OPTIONS:

1. LIFT-OFF LID
2. TILT BAGLOADER
3. EXPLOSION PROOF CLASSIFICATION
4. PROGRAMMABLE FEEDER CONTROL MODULE STAND
5. LIW SYSTEM "LOSS IN WEIGHT"

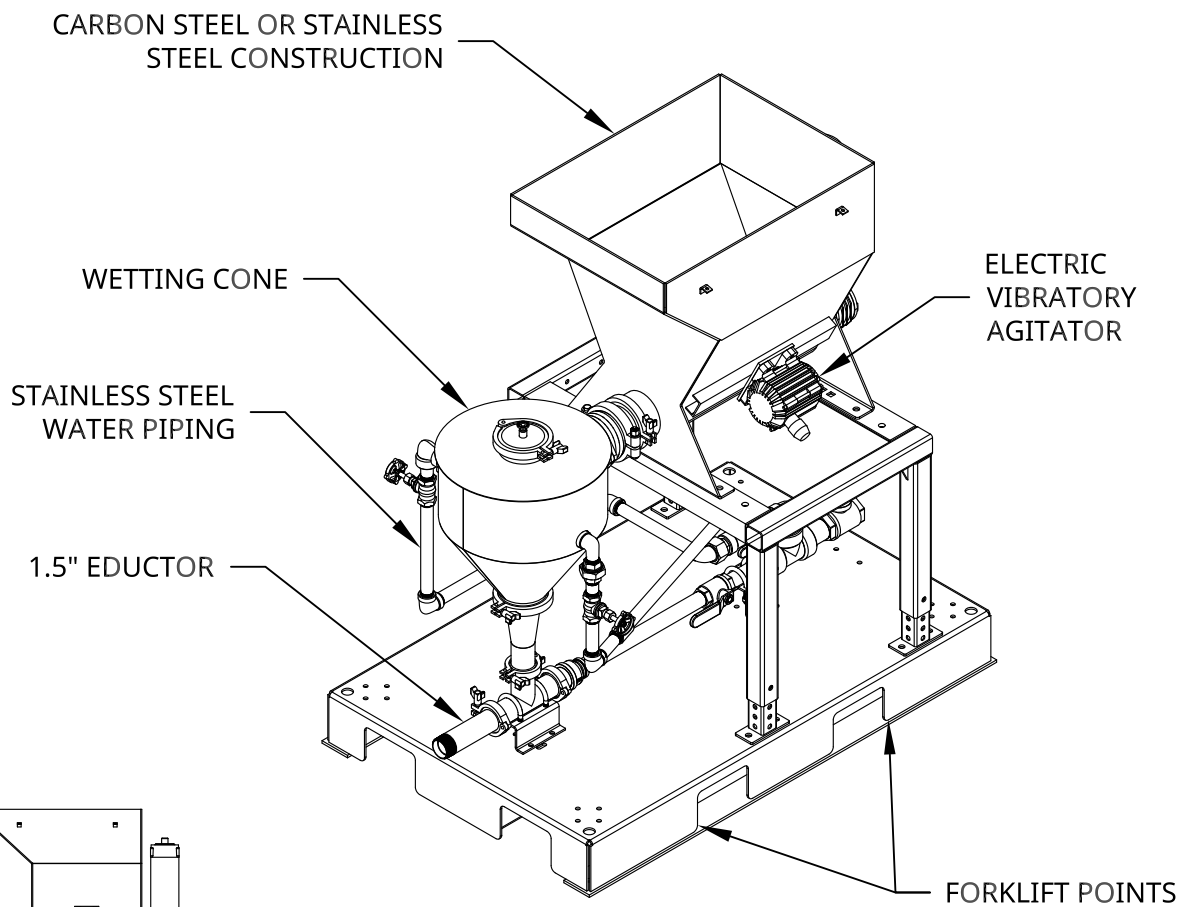
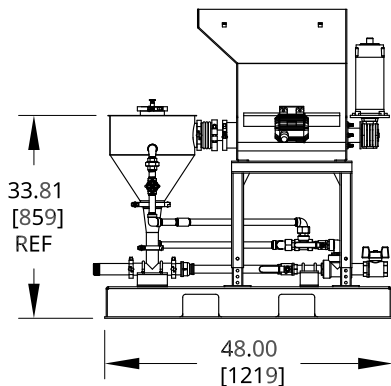
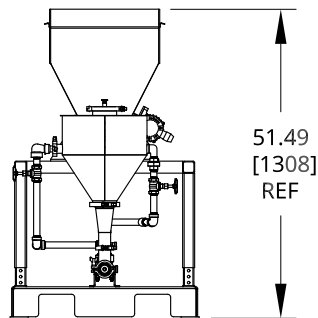
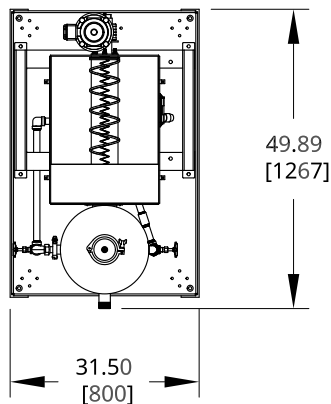

- VMF-90F STANDARDS:**
1. VOLUME OF VMF-90F IS 3.6 FT³
 2. 304 STAINLESS STEEL OR CARBON STEEL CONSTRUCTION
 3. 1.5" OPEN HELIX SCREW WITH CONCENTRIC MATERIAL CONDITIONING AUGER
 4. 115V/230V 1 PHASE 60 HZ 1/2 HP TENV 56 C FRAME 1750 RPM WASHGUARD™ MOTOR
 5. 60:1 GEAR RATIO / 29 RPM
 6. ELECTRIC VIBRATORY AGITATOR
 7. PROGRAMMABLE FEEDER CONTROL MODULE ENCLOSED IN NEMA 4X BOX



Bedminster Industrial Park
 53 Apple Tree Lane P.O. Box 365
 Plumsteadville, PA 18949 USA
 www.scaletronscales.com
 info@scaletronscales.com
 Toll Free: 1-800-257-5911 (USA & Canada)
 Phone: (+1) 215-766-2670 (International)
 Fax: (+1) 215-766-2672

SCALETRON MODEL VMF-90F VOLUMETRIC SCREW FEEDER SKID PACKAGE W/ WETTING CONE

DRAWN BY: KEH
DATE: 08/22/2018
SCALE: DO NOT SCALE

DRAWING NUMBER
MK19-U-02
 REV 02