

MODEL	A	B	C	D	E	F	G	GROSS CAPACITY
3000ST	20.5"/521mm	3.625"/92mm	3.875"/98mm	2.50"/64mm	18.50"/470mm	.580"/14.7mm	.625"/15.8mm	4000LB/1814KG

[PN: 3000ST]

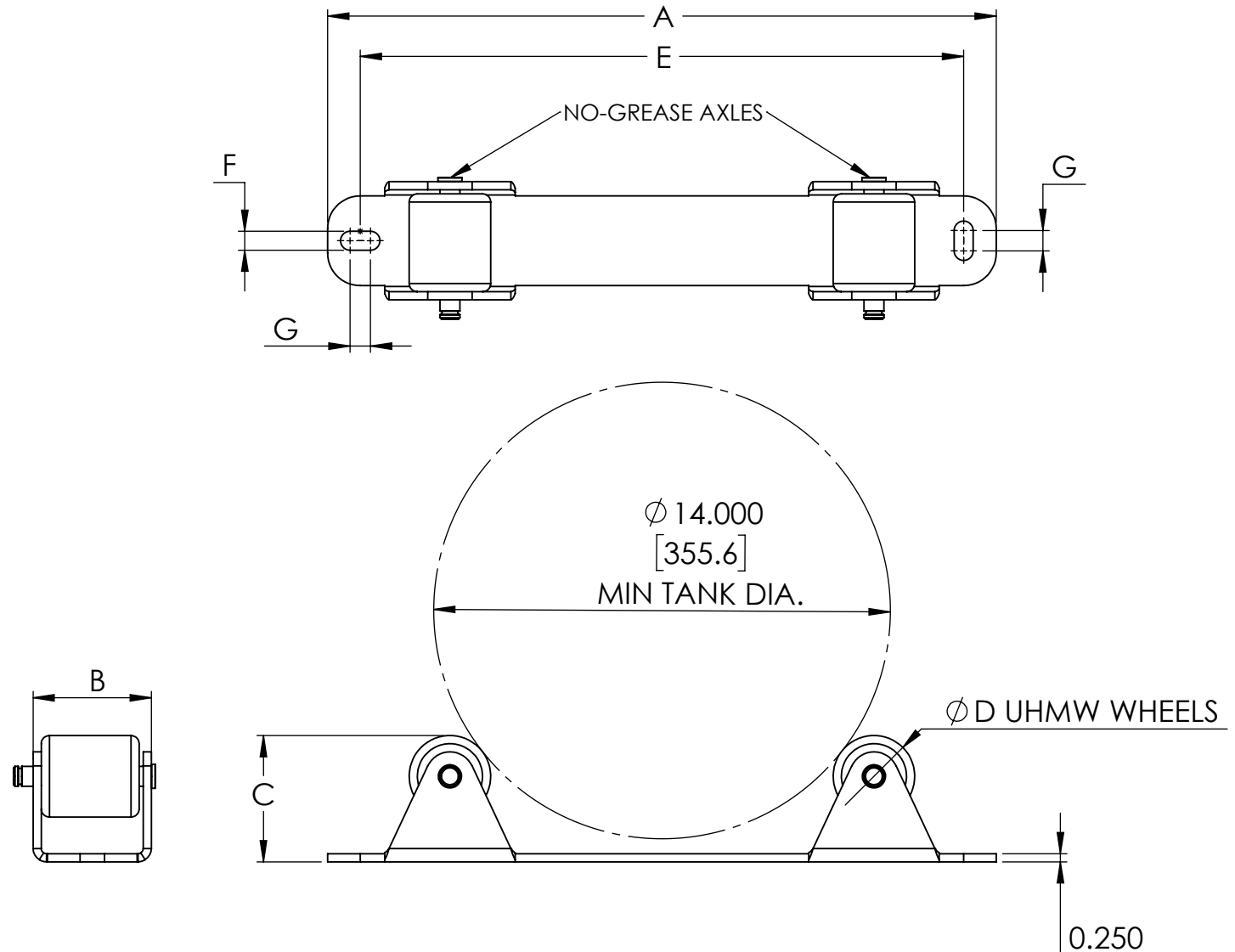

NOTES:
STANDARD CONSTRUCTION:
POWDER COATED STEEL



53 Apple Tree Lane
P.O. Box 365
Plumsteadville, PA 18949
Toll Free: (800) 257-5911
Phone: (215) 766-2670
Fax: (215) 766-2672
E-Mail: info@scaletronscales.com
Website: www.scaletronscales.com

NOTICE

THE INFORMATION CONTAINED IN THIS DRAWING IS THE SOLE PROPERTY OF SCALETRON INDUSTRIES LTD. ANY REPRODUCTION IN PART OR AS A WHOLE WITHOUT THE WRITTEN PERMISSION OF SCALETRON INDUSTRIES LTD IS PROHIBITED.

MODEL 3000ST
TON CYLINDER STORAGE TRUNIIONS
(2 PCS PER SET)

REV

CBC 8/11/2021