

MODEL	A	B	C	D	NET CAPACITY LB/KG			
4042-26-____	26.875"/683mm	26.875"/683mm	8.84"/225mm	28.20"/716mm	400LB/181KG	600LB/272KG	800LB/363KG	1000LB/454KG

[EX: 4042-26-800LB (OR 363KG)]

### TOP VIEW

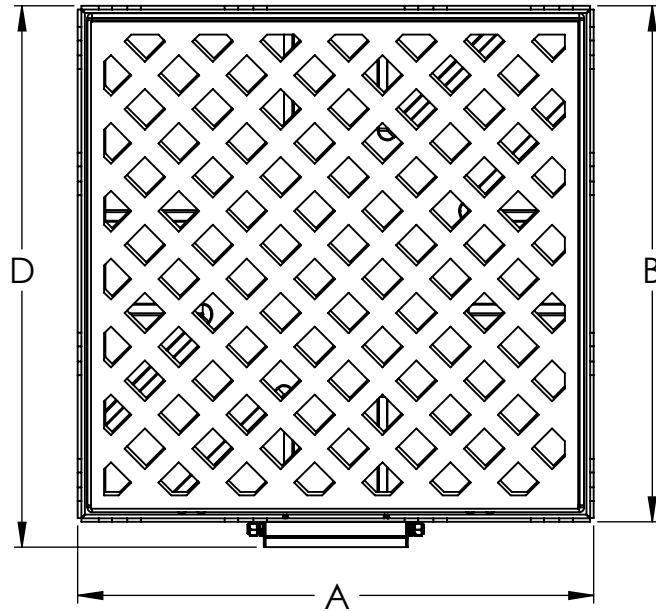

### SIDE VIEW (ROTATED 90°)

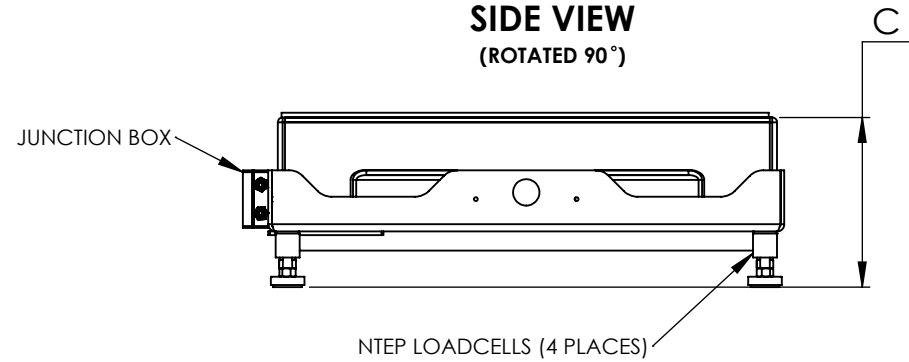

NOTES:  
 STANDARD CONSTRUCTION:  
 POWDER COATED STEEL  
 20'/6.1M LENGTH OF WIRE  
 11 GALLON CONTAINMENT CAPACITY



53 Appletree Lane  
 P.O. Box 365  
 Plumsteadville, PA 18949  
 Toll Free: (800) 257-5911  
 Phone: (215) 766-2670  
 Fax: (215) 766-2672  
 E-Mail: info@scaletronscales.com  
 Website: www.scaletronscales.com

**NOTICE**  
 THE INFORMATION CONTAINED IN THIS  
 DRAWING IS THE SOLE PROPERTY OF  
 SCALETRON INDUSTRIES LTD. ANY  
 REPRODUCTION IN PART OR AS A WHOLE  
 WITHOUT THE WRITTEN PERMISSION OF  
 SCALETRON INDUSTRIES LTD IS  
 PROHIBITED.

**MODEL 4042-26**  
 CONTAINMENT SCALE

REV

CBC 8/11/2021