

MODEL	A	B	C	D	NET CAPACITY LB/KG			
4042-63-_____	62.00"/1575mm	62.00"/1575mm	31.5"/800mm	65.75"/1670mm	5000LB/2268KG	6000LB/2722KG	7000LB/3175KG	8000LB/3629

[EX: 4042-63-5000LB OR 2268KG]

TOP VIEW

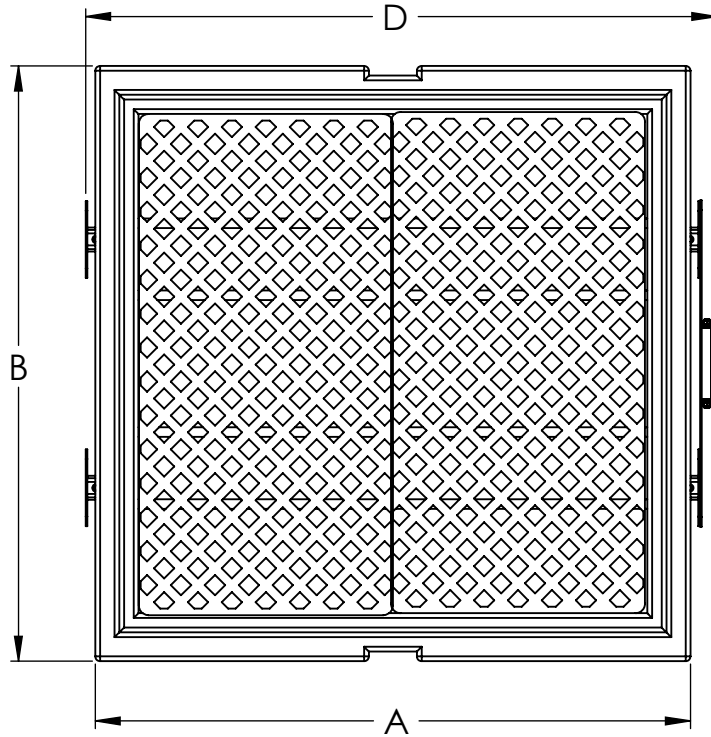

**SIDE VIEW
(ROTATED 90)**

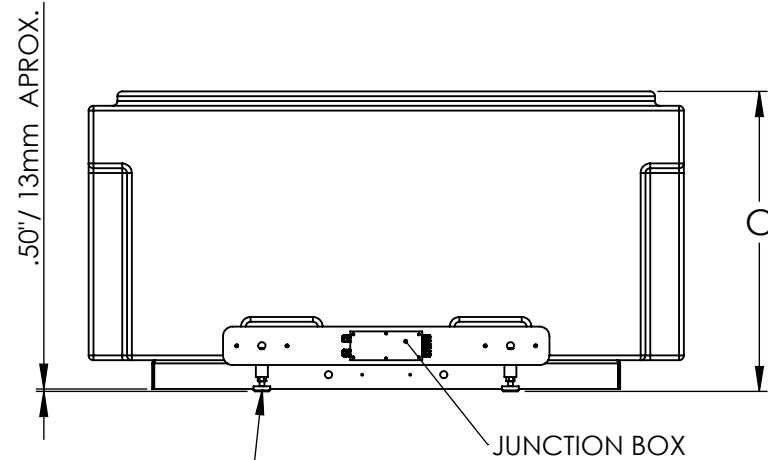

NTEP LOAD CELLS
ADJUSTABLE HEIGHT LEVELING FEET
(4 PLACES)

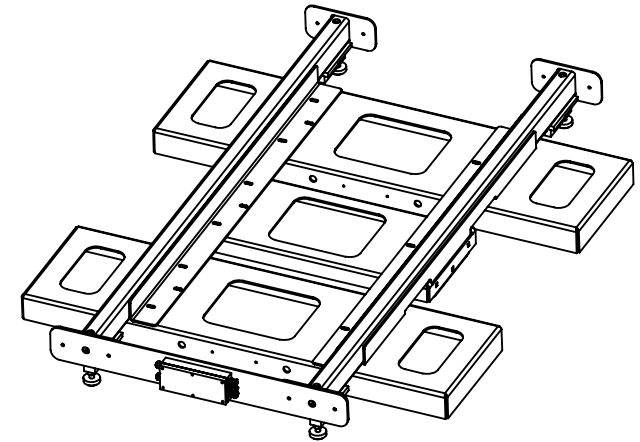

WITHOUT CONTAINMENT

NOTES:

STANDARD CONSTRUCTION:
POWDER COATED STEEL
20'/6.1M LENGTH OF WIRE
365 GALLON CONTAINMENT CAPACITY



53 Appletree Lane
P.O. Box 365
Plumsteadville, PA 18949
Toll Free: (800) 257-5911
Phone: (215) 766-2670
Fax: (215) 766-2672
E-Mail: info@scaletronscales.com
Website: www.scaletronscales.com

NOTICE

THE INFORMATION CONTAINED IN THIS DRAWING IS THE SOLE PROPERTY OF SCALETRON INDUSTRIES LTD. ANY REPRODUCTION IN PART OR AS A WHOLE WITHOUT THE WRITTEN PERMISSION OF SCALETRON INDUSTRIES LTD IS PROHIBITED.

MODEL 4042-63
IBC TOTE CONTAINMENT SCALE

REV

CBC 8/11/2021