

MODEL	A	B	C (Max)	E	F	NET CAPACITY LB/KG			
4042ECOWB-26-____	25.88"/657mm	24.00"/610mm	7.0"/178mm	34.00"/834mm	26.25"/667mm	400LB/181KG	600LB/272KG	800LB/363KG	1000LB/454KG

[EX: 4042ECOWB-26-800LB (OR 363KG)]

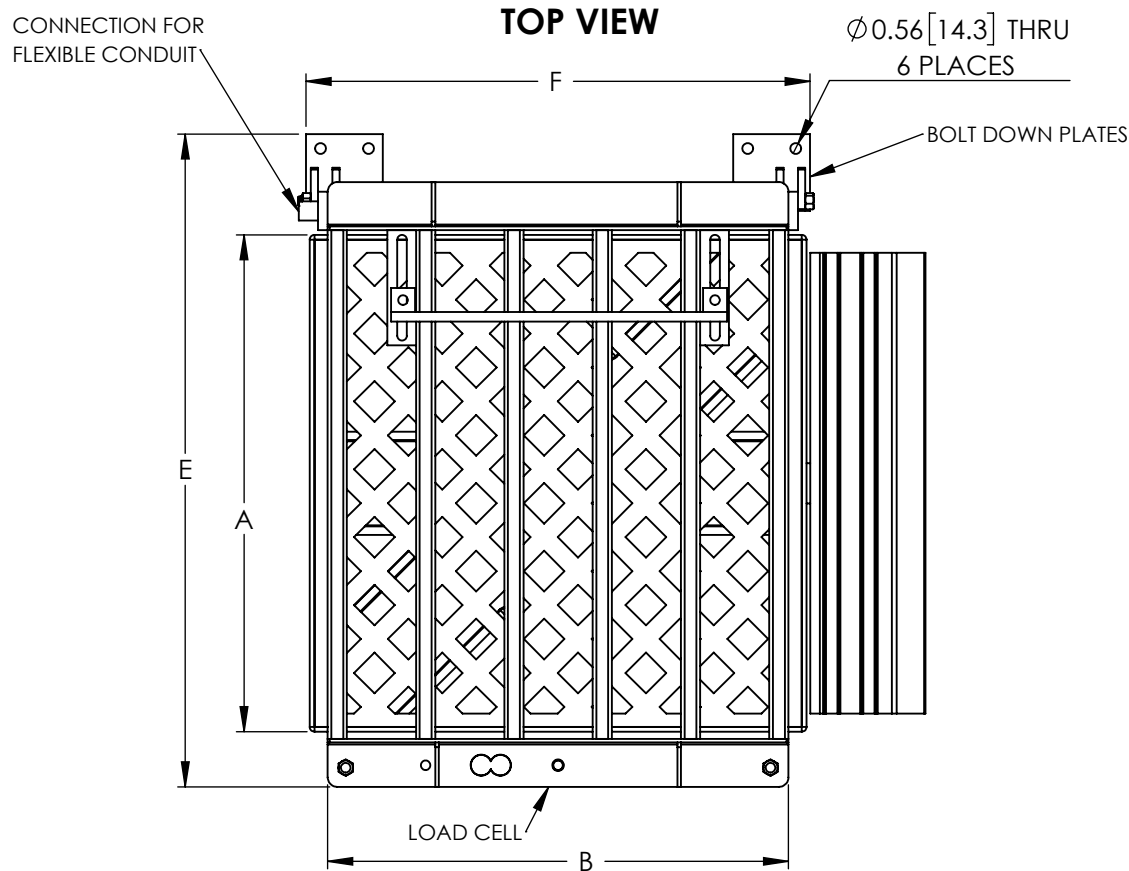

SIDE VIEW
(ROTATED 90°)

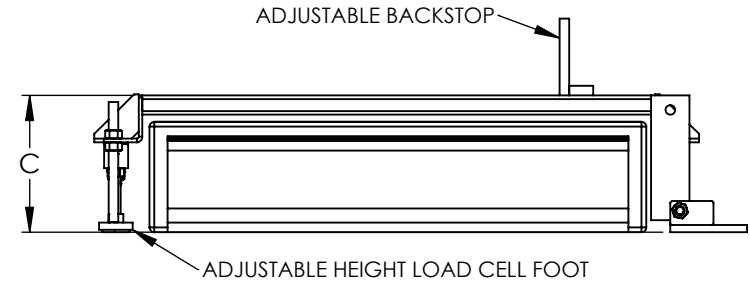

NOTES:
STANDARD CONSTRUCTION:
POWDER COATED STEEL
20'/6.1M LENGTH OF WIRE
11 GALLON CONTAINMENT
WEIGHS CENTERED TANKS 18"-26" DIAMETER



53 Appletree Lane
P.O. Box 365
Plumsteadville, PA 18949
Toll Free: (800) 257-5911
Phone: (215) 766-2670
Fax: (215) 766-2672
E-Mail: info@scaletronscales.com
Website: www.scaletronscales.com

NOTICE

THE INFORMATION CONTAINED IN THIS DRAWING IS THE SOLE PROPERTY OF SCALETRON INDUSTRIES LTD. ANY REPRODUCTION IN PART OR AS A WHOLE WITHOUT THE WRITTEN PERMISSION OF SCALETRON INDUSTRIES LTD IS PROHIBITED.

MODEL 4042ECOWB-26
ECO SPILL CONTAINMENT SCALE

REV

CBC 8/11/2021