

| MODEL | A | B | C | E | F | NET CAPACITY FOR EACH SCALE LB/KG | | | |
|--------------------|--------------|-------------|------------|-------------|--------------|-----------------------------------|-------------|-------------|--------------|
| 4042ECO-26X52-____ | 25.88"/657mm | 24.0"/610mm | 7.0"/178mm | 34.0"/864mm | 53.4"/1357mm | 400LB/181KG | 600LB/272KG | 800LB/363KG | 1000LB/454KG |

[EX: 4042ECO-26X52-800LB (OR 363KG)]

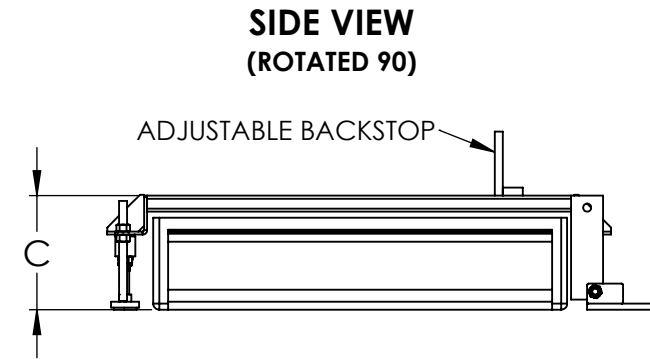
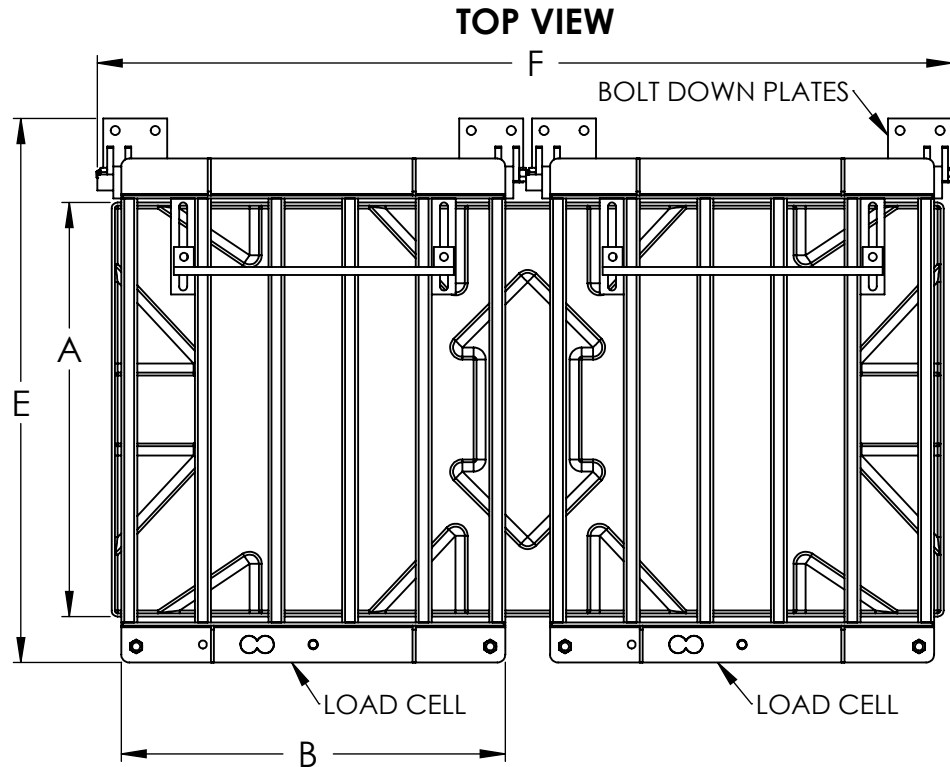

NOTES:

STANDARD CONSTRUCTION:
 POWDER COATED STEEL
 20'/6.1M LENGTH OF WIRE
 CONTAINMENT CAPACITY: 22 GAL.



53 Appletree Lane
 P.O. Box 365
 Plumsteadville, PA 18949
 Toll Free: (800) 257-5911
 Phone: (215) 766-2670
 Fax: (215) 766-2672
 E-Mail: info@scaletronscales.com
 Website: www.scaletronscales.com

NOTICE

THE INFORMATION CONTAINED IN THIS DRAWING IS THE SOLE PROPERTY OF SCALETRON INDUSTRIES LTD. ANY REPRODUCTION IN PART OR AS A WHOLE WITHOUT THE WRITTEN PERMISSION OF SCALETRON INDUSTRIES LTD IS PROHIBITED.

MODEL 4042ECO-26X52

REV

CBC 10/11/2021