

MODEL	A	B	C	D	E	F	NET CAPACITY FOR EACH SCALE LB/KG			
4042ECO-26X52-_____	25.88"/657mm	24.0"/610mm	7.0"/178mm	57.95"/1472mm	34.0"/864mm	53.4"/1357mm	400LB/181KG	600LB/272KG	800LB/363KG	1000LB/454KG

[EX: 4042ECO-26X52-800LB (OR 363KG)]

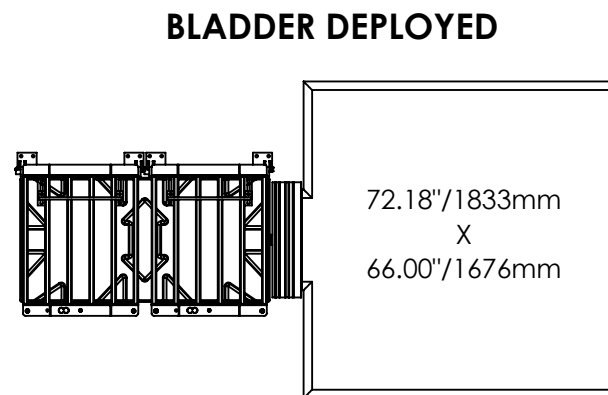

NOTES:
 STANDARD CONSTRUCTION:
 POWDER COATED STEEL
 20'/6.1M LENGTH OF WIRE
 CONTAINMENT CAPACITY: 22 GAL.
 WITH SINGLE BLADDER: 88 GAL.
 WITH 2 BLADDERS: 154 GAL.

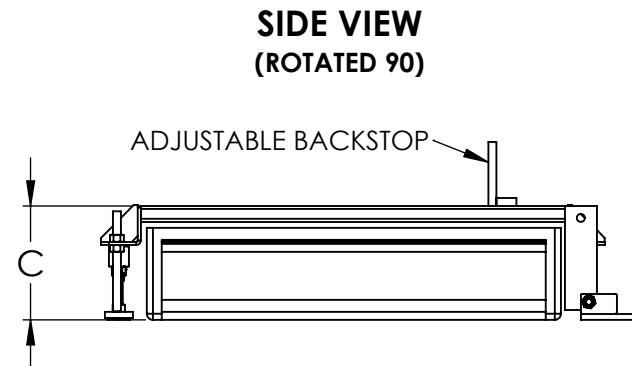
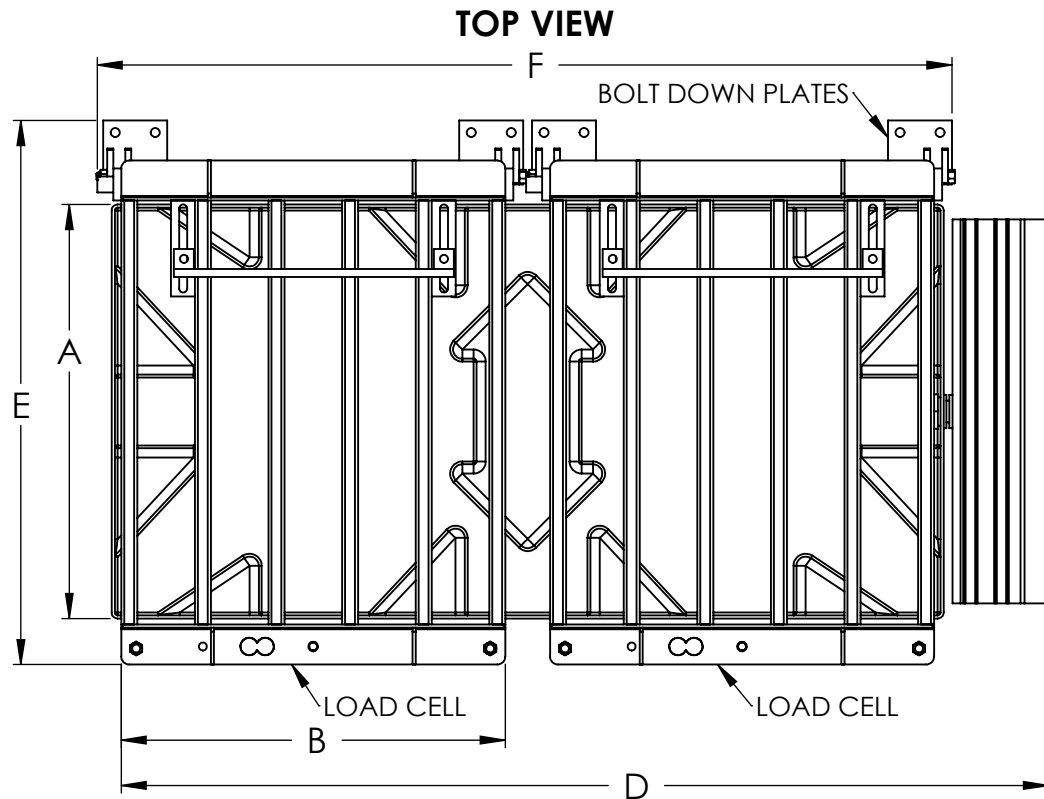

53 Appletree Lane
 P.O. Box 365
 Plumsteadville, PA 18949
 Toll Free: (800) 257-5911
 Phone: (215) 766-2670
 Fax: (215) 766-2672
 E-Mail: info@scaletronscales.com
 Website: www.scaletronscales.com

NOTICE
 THE INFORMATION CONTAINED IN THIS
 DRAWING IS THE SOLE PROPERTY OF
 SCALETRON INDUSTRIES LTD. ANY
 REPRODUCTION IN PART OR AS A WHOLE
 WITHOUT THE WRITTEN PERMISSION OF
 SCALETRON INDUSTRIES LTD IS
 PROHIBITED.

MODEL 4042ECOWB-26X52

REV

CBC 10/11/2021