

MODEL	DESCRIPTION	NET CAPACITY LB/KG
3050-1-2000LB	SINGLE TON CYLINDER MODEL	907KG OR 1000KG/2000LB
3050-2-4000LB	DUAL TON CYLINDER MODEL	1814KG OR 2000KG/4000LB

TOP VIEW

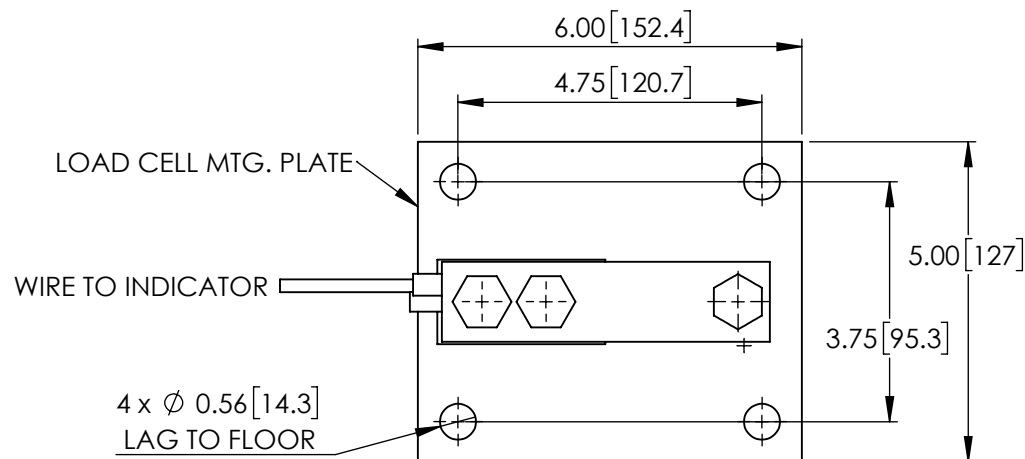

SIDE VIEW

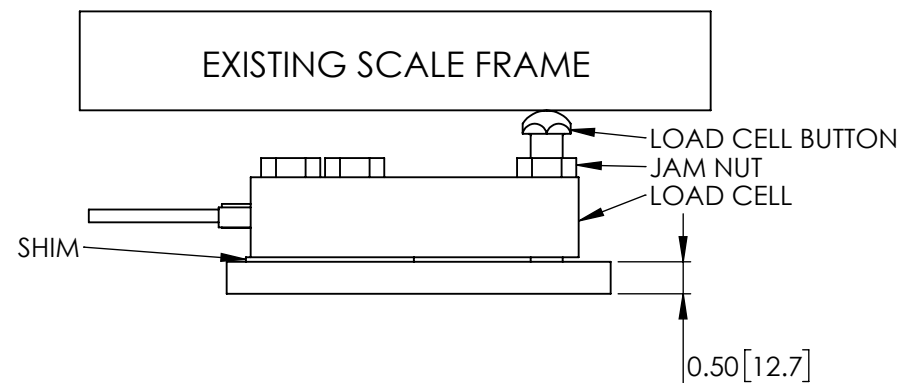

NOTES:

STANDARD CONSTRUCTION:
POWDER COATED STEEL
20'/6.1M LENGTH OF WIRE



53 Apple Tree Lane
P.O. Box 365
Plumsteadville, PA 18949
Toll Free: (800) 257-5911
Phone: (215) 766-2670
Fax: (215) 766-2672
E-Mail: info@scaletronscales.com
Website: www.scaletronscales.com

NOTICE

THE INFORMATION CONTAINED IN THIS DRAWING IS THE SOLE PROPERTY OF SCALETRON INDUSTRIES LTD. ANY REPRODUCTION IN PART OR AS A WHOLE WITHOUT THE WRITTEN PERMISSION OF SCALETRON INDUSTRIES LTD IS PROHIBITED.

MODEL 3050
TON CYLINDER CONVERSION KIT

REV

CBC 12/15/2021