

SECTION A-A
SCALE 1:24

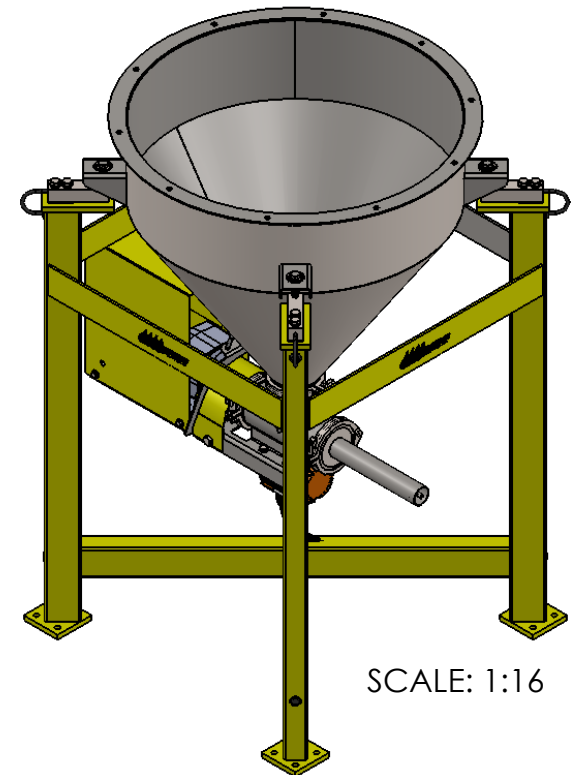
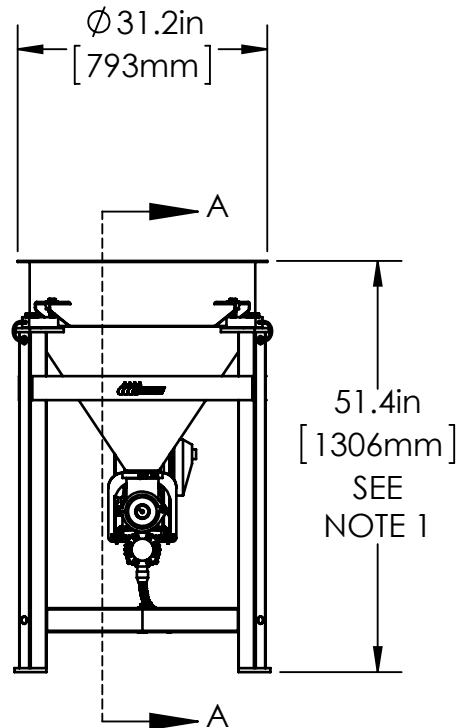

NOTES: UNLESS OTHERWISE SPECIFIED
1. DIMENSION WILL CHANGE DEPENDING UPON APPLICATION

UNLESS OTHERWISE SPECIFIED:
DIMENSIONS ARE IN INCHES

TOLERANCES:
FRACTIONAL ±1/32"
ANGULAR: MACH ±1°
..... BEND ±1°
TWO PLACE DECIMAL ±.01
THREE PLACE DECIMAL ±.005

MATERIAL
FINISH
DO NOT SCALE DRAWING

PROPRIETARY AND CONFIDENTIAL
THE INFORMATION CONTAINED IN THIS DRAWING IS THE SOLE PROPERTY OF SCALETRON INDUSTRIES LTD. ANY REPRODUCTION IN PART OR AS A WHOLE WITHOUT THE WRITTEN PERMISSION OF SCALETRON INDUSTRIES LTD IS PROHIBITED.

	NAME	DATE
DRAWN	JMS	3/8/17
CHECKED		
ENG APPR.		
MFG APPR.		
Q.A.		



TITLE: VMF-28
BASE MODEL
DIMENSIONS

SIZE A	DWG. NO. VMF-28-001	REV -
------------------	------------------------	----------

SCALE: 1:24 SHEET 1 OF 1