



SCALETRON™ SETS THE STANDARD
IN CORROSION RESISTANCE™

Model AccuPro 7000-TS™ Digital Scale Controller with Touch Screen

- One (1) to four (4) channel operation
- Touch screen interface
- High accuracy of ± 0.1 to $\pm 0.25\%$ of capacity
- Alphanumeric/graphic color LCD display with easy readability to 0.1 lb. (kg)
- Displays net and gross weight and %, bar graphs, mA out, tare, set points, feed rate, daily usage, batch and total amount, time to complete
- Readout in pounds, kilograms, gallons or liters
- 4-20 mA outputs and optional set point relays



Advanced Digital Scale Controller with Up to 4 Channels Offers Touch Screen Input

The Model AccuPro 7000-TS Digital Scale Controller is designed for use with Scaleton's complete line of cylinder, ton cylinder, drum, tank, platform, IBC tote and spill containment scale bases. Featuring an easy to read 4.3" alphanumeric/graphic color LCD touch screen display and a new simplified menu system, the controller provides an excellent accuracy of $\pm 0.1\%$ to $\pm 0.25\%$ of full scale capacity and will display net weight or gross weight in pounds, kilograms, gallons or liters. Controller is available with up to four (4) channels with optional 4-20 mA outputs. The 4-20mA output (scale powered) is scalable to a user defined value, and is adjustable. Options include high and low set point relay contacts and an audible alarm. The 7000 series allows the user to easily adjust any setting on the spot including adjusting the tare value or selecting a unit directly from any weight display.

Standard Features

- Electronic indicator housed in NEMA 4X, UL approved wall mount enclosure to provide protection from acids
- Displays net and gross weight; net and gross percent (%); net and gross weight bar graphs; mA out, tare adjustment and set point values; on-screen and memory-stored historical data log, feed rate, daily usage, current amount used and days till empty
- Batch control process that displays net weight, set batch amount, total amount and time to complete
- Up to eleven (11) single-channel and nine (9) multi-channel weight displays
- Leak detector input
- Compatibility with all Scaleton scales
- Ability to mix different scale types on one controller
- Simplified menu system for ease of operation
- Status check menu for errors, alarms, set points, and load cell(s) check function to ensure stable operation

- Password protection
- Field programmable and calibratable including factory restore setting
- 6 Foot power cord

Options

- 4-20 mA analog output for each channel – net weight or feed rate
- High and low level set point relay contacts – 4 per channel, maximum 8 total Alarm active, weight set point active and max net weight relays
- Audible alert/alarm with external buzzer support
- Remote mounting of indicator box up to 200 feet (61 meters) away from scale base
- Remote monitoring capabilities with either Modbus TCP through ethernet or Modbus RTU via RS-232/RS-485 serial network

Model AccuPro 7000-TS™ Digital Scale Controller with Touch Screen

Display Screens

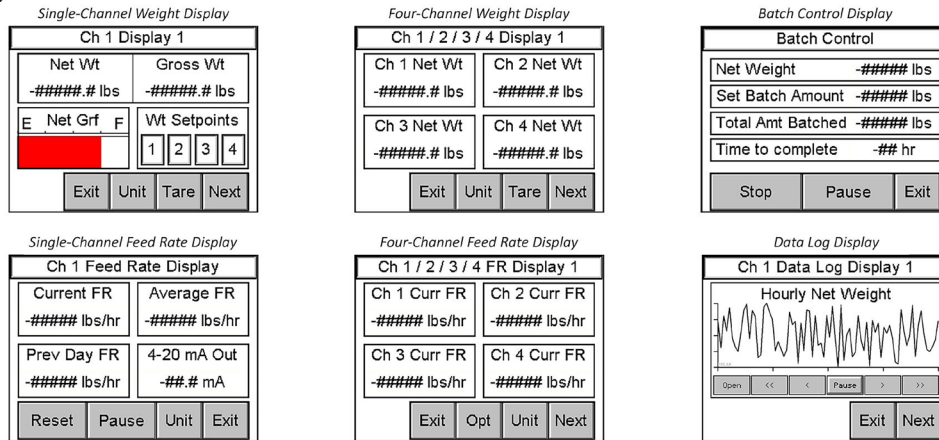

Dimensions

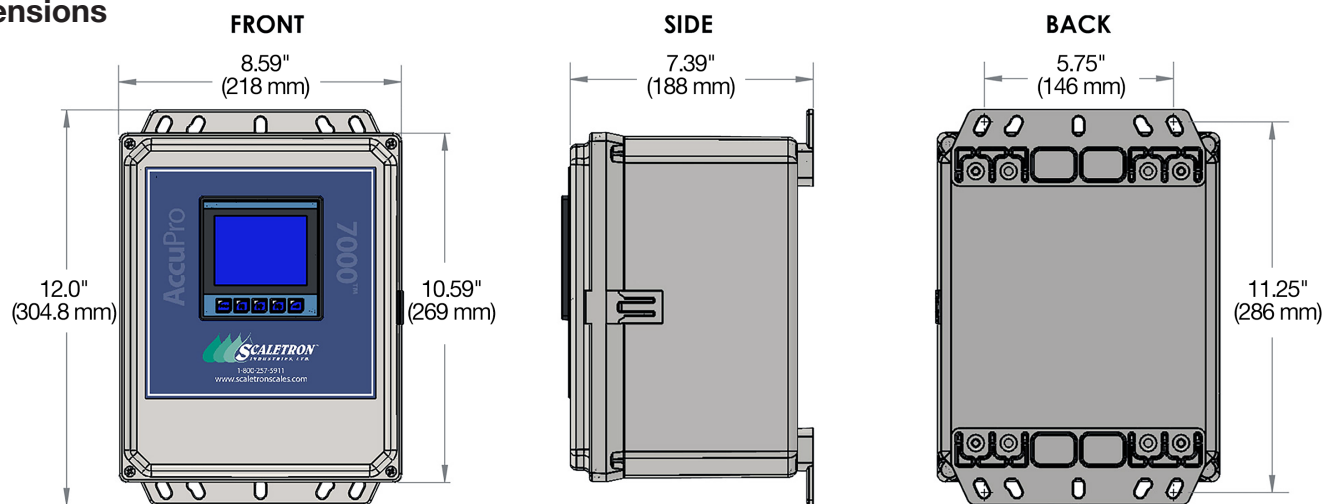

Specifications

PART NUMBER	ACCUPRO 7000-TS	PART NUMBER	ACCUPRO 7000-TS
Interface	Touch screen	Set Points	2 or 4 Relay contacts optional per channel (high or low), maximum 8 total - dry contact 3A relay with N.O and N.C connection
Accuracy	±0.1% to ±0.25% of full scale capacity	Remote Option	Can be remotely mounted up to 200 feet from base frame
Display	4.3" Alphanumeric/graphic color LCD touch screen display with adjustable brightness	Audible Alarm	Optional 78 dB internal piezo buzzer, external buzzer support
Display Items	Displays net and gross weight; net and gross percent (%); net and gross weight bar graphs; mA out, tare adjustment and set point values; on-screen and memory-stored historical data log, feed rate, daily usage, current amount used and days till empty; batch net weight, batch and total amount and time to complete	Communication Option	Remote monitoring with either Modbus TCP through ethernet or Modbus RTU via RS-232/RS-485 serial network
Display Screens	Up to eleven (11) single-channel and nine (9) multi-channel weight displays	Power	100/277 VAC, 50/60 Hz, 0.10/0.05A
Display Units	Pounds, kilograms, gallons or liters	Enclosure	NEMA 4X, UL approved wall mount enclosure
Channels	Up to 4 - One scale base per channel	Weight	7 lbs.
Output Signal	4-20mA Optional - 1 Output per channel, scale powered		

Scaleton Industries Ltd.

Bedminster Industrial Park
53 Apple Tree Lane • P.O. Box 365
Plumsteadville, PA 18949 • USA

Tel: (+1) 215-766-2670 (International)
Tel: (+1) 800-257-5911 (USA & Canada)
Fax: (+1) 215-766-2672

Email: info@scaletonscales.com
Website: www.scaletonscales.com