

Adapter flange matches Wallace & Tiernan 32-055

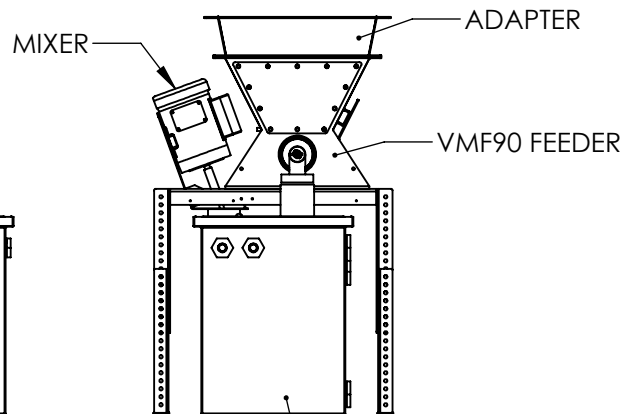

MAY FEED A HOLDING TANK OR AN EDUCATOR.
35 GALLON TANK SHOWN. OTHER SIZES ARE AVAILABLE.

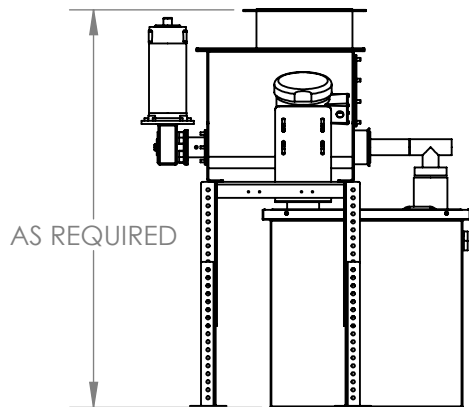
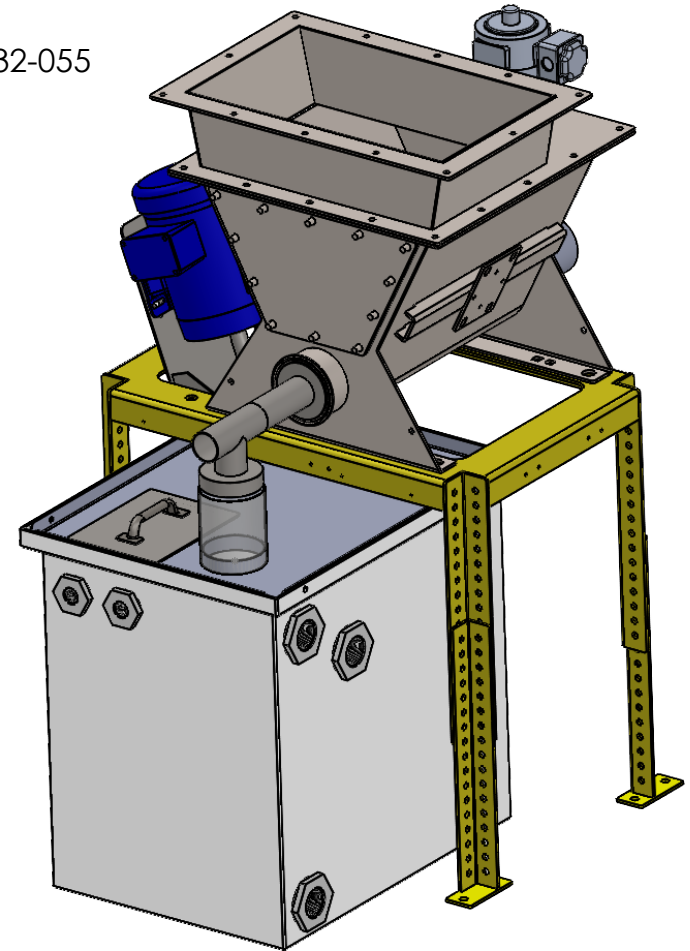

53 Apple Tree Lane P.O. Box 365 Plumsteadville, PA 18949
Toll Free: (800) 257-5911 Phone: (215) 766-2670 Fax: (215) 766-2672
E-Mail: info@scaletronscales.com Website: www.scaletronscales.com

NOTICE
THE INFORMATION CONTAINED IN THIS DRAWING IS THE SOLE PROPERTY OF SCALETRON INDUSTRIES LTD. ANY REPRODUCTION IN PART OR AS A WHOLE WITHOUT THE WRITTEN PERMISSION OF SCALETRON INDUSTRIES LTD IS PROHIBITED.

DRAWN BY: CBC ON 12/7/23

MATERIAL: N/A ID

WEIGHT (LBS): 170 LBS AS SHOWN

DIMENSIONS ARE IN INCHES
TOLERANCES UNLESS OTHERWISE SPECIFIED:
TWO PLACE DECIMALS: +/- .010
THREE PLACE DECIMALS: +/- .005
ANGLES: +/- 1°
SHEET METAL BENDS: +/- .020

W&T Direct Replacement Feeder

PN: VMF90 W&T REPLACEMENT

REV B
REV C
REV D

REV E
REV F
REV G

LAST SAVED: Wednesday, December 6, 2023 4:24:53 PM

REV
A

SHEET
1/1