

Model 2305™ Eco Cylinder Scale Base [PN: 2305-150LB or 2305-68KG (or 70KG)]:

The Model 2305™ Eco-Scale is assembled and calibrated at the factory, then partially disassembled for shipment. Some reassembly and set-up is required before the scale can be operated.

Assembly and Start Up Instructions:

Before assembly, take note of the scale base and indicator serial numbers. The scale base and indicator serial numbers must match each other for proper operation! If configured with dual channel indicator: Ch 1 = blue heat shrink tubing, Ch 2 = yellow heat shrink tubing. Refer to controller installation instructions for guidance on wiring. Do not loosen or move load cell.

Base Anchoring, Installation & Wiring:

Step 1: Refer to controller installation instructions for guidance on wiring. Do not loosen or move load cell.

Remove all parts from carton and inspect for damage – bent metal, broken wires, cracks in digital controller, etc. Any shipping damage must be reported **to carrier!**

Parts Bag contains:

- 1) 33" chain, 1) tool tray, & 6) 'S' hooks for cylinder restraint and tool hangers
- 1) black plastic strain relief & nut
- 1) Flat washer for anchor screw under load cell
- 3) leveling shims
- 3) masonry screws for mounting scale base to floor
- 1) silicone grease for sealing load cell to mounting socket

Step 2: Mount the digital controller, tool rack w/ cylinder restraint chains and hooks on the wall. The base *must* be leveled for accurate readings by placing shims under the base. **IMPORTANT:** Base *must* be anchored 5" from the wall to avoid interfering with the cylinder on the scale.

Step 3: Place the scale on a solid, dry, and even surface. Clear the area of all debris where the scale base will be anchored.

Step 4: Refer to 2305 anchoring, installation & wiring drawings below:

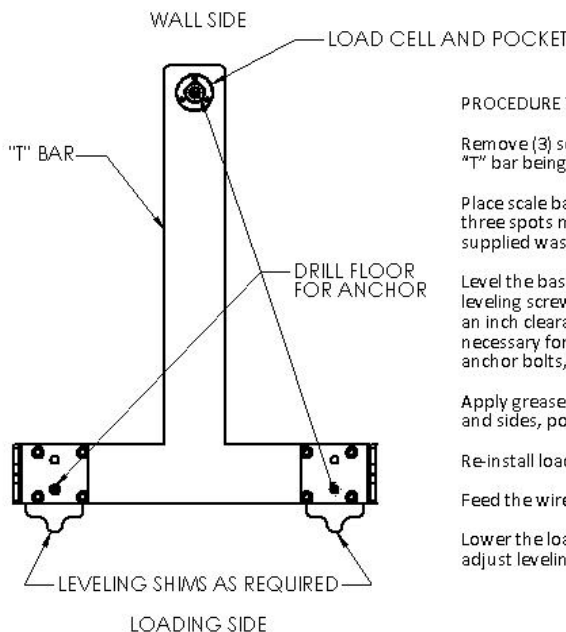

PROCEDURE TO INSTALL MODEL 2305™'S SCALE BASE:

Remove (3) screws that hold the load cell in the load cell pocket on "T" bar being careful not to pull on the load cell.

Place scale base where it is to be installed. Drill holes in floor at the three spots marked for anchors. Install anchor bolts using the supplied washer under the load cell - do not tighten yet.

Level the base in both directions using shims as required. Adjust leveling screw on top of scale, making sure there is at least .040 of an inch clearance between "T" bar and scale platform. This is necessary for scale to function correctly. When level, tighten (3) anchor bolts, check level again.

Apply grease supplied, to thoroughly coat the load cell top, bottom and sides, pocket in "T" bar, contact surface and holes in load cell.

Re-install load cell with (3) screws.

Feed the wire through the strain relief and finger-tighten the nut.

Lower the load plate onto the load cell gently, do not drop, and adjust leveling screw again if necessary.

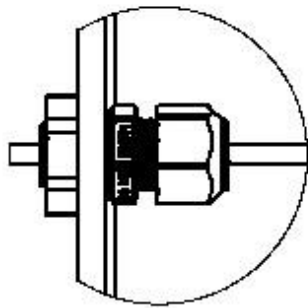
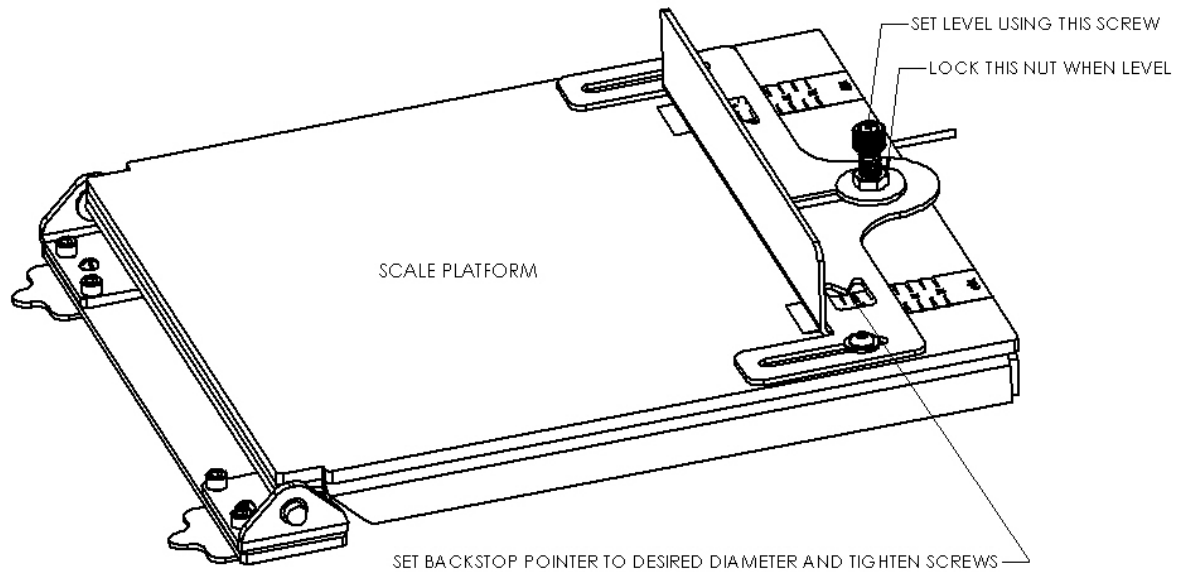

Route the wire as shown.
The loop is needed to allow the deck to be lifted.
Pass the wire through the strain relief,
hand-tighten the nut on the strain relief.

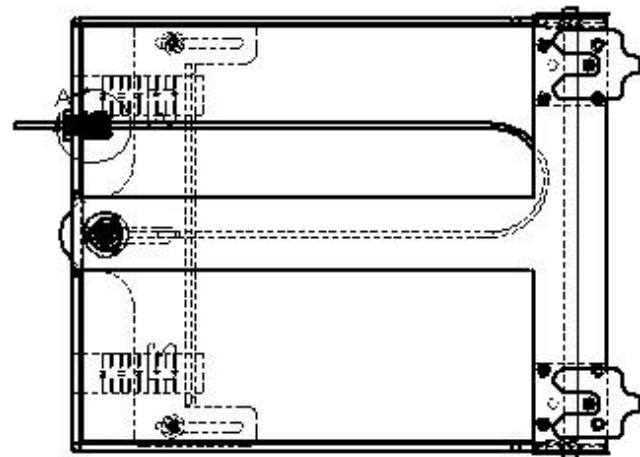

*****See controller manual for rest of set-up and operating instructions.*****

Replacement Parts:

PN: 2305LC – Canister load cell for Model 2305