

Model 4042ECOWB™ Spill Containment Scale Base with bladder
(PN: 4042ECOWB- (enter size of base) – (enter net capacity in LB or KG):

Assembly and Start Up Instructions:

Before assembly, take note of the scale base and indicator serial numbers. The scale base and indicator serial numbers must match each other for proper operation! If configured with dual channel indicator: Ch 1 = blue heat shrink tubing, Ch 2 = yellow heat shrink tubing. Refer to controller installation instructions for guidance on wiring. Do not loosen or move load cell. The Model 4042ECOWB™ Spill Containment Scale with bladder is assembled and calibrated to the digital controller at the factory, then partially disassembled for shipment. **Depending on size of containment basin, sometimes they are shipped direct from the manufacturer and will arrive separate from scale base and controller.**

Set up and Wiring:

Step 1: Remove all parts from box and inspect for damage – bent metal, broken wires, cracks in indicator, etc. **Any shipping damage must be reported to carrier!**

Parts Bag Contains: (Tie wrapped to scale base)

- 1) leveling foot w/ jam nut

Bladder Installation Parts: (inside box with bladder)

- 1) washer
- 1) Plastic gasket
- 1) Left Handed Threaded Nut

Step 2: Place the scale base on solid, dry, and even surface. Clear the area of all debris where the scale base will be set up.

Step 3: VERY IMPORTANT: Make sure that expandable bladder has room and clearance to expand without coming into contact with any other objects that may cause a leak or obstruct proper expansion of the bladder!!!

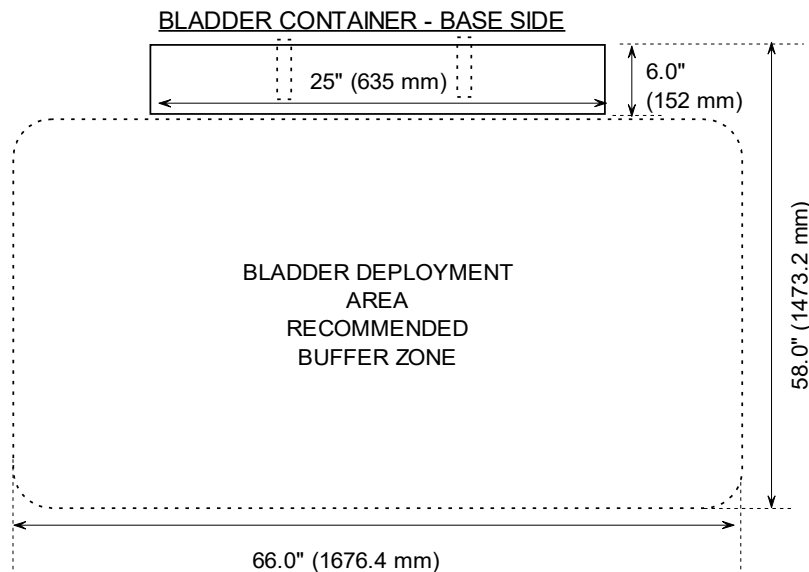

STEP 4: Position pivot plates on the floor so the base is in the desired position. Floor must be close to level, but if the base is out of level from side to side, shim pivot plates to level scale from side to side and prepare anchor bolts. Mark and drill (3) holes per pivot plate into concrete and anchor with lag bolts.

STEP 5: *This leveling adjustment is critical to accurate operation of the scale.* Place level on top of scale base from front to back and adjust leveling foot to level scale base. Tighten the nut on the load cell leveling foot stud so that foot does not twist off of level. Nut should be a little more than hand tightened.

Step 6: Make sure the anti-tipping side bolts are not touching the floor, but are capable of stopping the base from tipping.

Step 7: Place Containment basin under scale base and install bladder using below instructions:

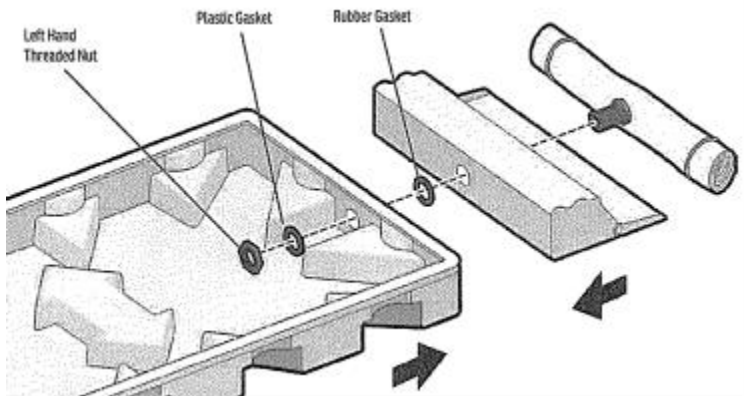

Step 8: If conduit is to be used, we recommend at least 2 feet of horizontally mounted, FLEXIBLE conduit as to not interfere with free movement of the base for accurate measurement. Feed the wire up through the conduit, and apply a fitting.

*****See controller manual for rest of set-up and operating instructions.*****

Replacement Parts:

PN: **SB/SS-** (*enter load cell value*) **-LC** : replacement load cell & shim
PN: **4042ECOLF** : leveling foot & jam nut for Model 4042ECOWB scale base
PN: **4042-CB26** : 26" Replacement Spill Containment Basin (11 gal)
PN: **4042-CB26x52** : 26"x52" Replacement Spill Containment Basin (22 gal)
PN: **4042-CB52x52** : 52"x52" Replacement Spill Containment Basin (44 gal)
PN: **4042BO** : Complete bladder attachment
PN: **4042RB** : Replacement Bladder Bag *ONLY*