



# AccuPro 1000™ Operator's Manual

**Scaleton Industries, LTD 53 Appletree Lane Plumsteadville, PA 18949**

**Toll Free: 1-800-257-5911 (USA & Canada)**

**Phone: (+1) 215-766-2670 (International)**

**Fax: (+1) 215-766-2672**

**[info@scaletonscales.com](mailto:info@scaletonscales.com)**

All information contained in this document is confidential to Scaleton Industries, Ltd. No license is expressed or implied, under any patent, copyright or trade secret right is granted or implied by the conveyance of this document. No part of this document may be reproduced, transmitted, transcribed, stored in a retrieval system, translated into any language or computer language, in any form or by any means, electronic, mechanical, magnetic, optical, chemical, manual, or otherwise without the prior written permission of Scaleton Industries, Ltd

## Table of Contents

<b>1 Introduction.....</b>	<b>6</b>
1.1 Scope .....	6
1.2 Acronyms and Abbreviations.....	6
1.3 Definitions.....	7
1.4 Factory Options.....	7
<b>2 Specifications .....</b>	<b>8</b>
<b>3 Indicator Assembly and Configuration .....</b>	<b>10</b>
3.1 Enclosure Preparation and Mounting .....	11
3.2 Hardware Layout .....	12
3.3 Scale Base Input Wiring .....	18
3.4 mA Output Type Selection .....	19
3.5 mA Output Wiring .....	20
<b>4 System Operation and Navigation .....</b>	<b>23</b>
4.1 Startup Sequence .....	23
4.2 Button Functions and Layout .....	24
<b>5 Configuration Menu .....</b>	<b>25</b>
5.1 Display Unit .....	26
5.2 Display Decimal .....	27
5.3 Weight Stability .....	28
5.4 4-20 mA Output .....	29
5.5 Specific Gravity .....	33
5.6 Calibration .....	34
<b>6 Weight Display .....</b>	<b>40</b>



**7 Tare Adjustment .....41**

7.1 Tare Mode: Edit Tare .....42

7.2 Tare Mode: Edit Net .....43

7.3 Tare Errors .....44

**8 System Info Menu .....45**

8.1 Base Input Signal .....46

8.2 Max Gross .....47

8.3 Calibration Data .....48

8.4 Errors .....49

8.5 Software Version .....50

8.6 Serial Number .....51

**9 Errors and Troubleshooting .....52**

9.1 Critical Errors .....52

9.2 Operational Errors .....53

## Figure List

Figure 1: Enclosure Contents .....	10
Figure 2: Indicator Front View .....	13
Figure 3: Control Board .....	14
Figure 4: Control Board LEDs .....	15
Figure 5: Display Board.....	16
Figure 6: Display Board LEDs .....	17
Figure 7: Scale Base Input Wiring Connection .....	18
Figure 8: mA Output Type Selection .....	19
Figure 9: mA Output Wiring Connection .....	20
Figure 10: Scale (Self-Powered) mA Output Wiring Diagram .....	21
Figure 11: Loop (Loop-Powered) mA Output Wiring Diagram .....	22
Figure 12: Configuration Menu .....	25
Figure 13: Display Unit .....	26
Figure 14: Display Decimal .....	27
Figure 15: Weight Stability.....	28
Figure 16: 4-20 mA Output .....	29
Figure 17: 20 mA Value .....	30
Figure 18: Adjust 4 mA Trim .....	31
Figure 19: Adjust 20 mA Trim .....	32
Figure 20: Specific Gravity .....	33
Figure 21: Calibration Password.....	34
Figure 22: Calibration Step 1: Calibration Unit .....	35
Figure 23: Calibration Step 2: Max Gross Weight .....	36
Figure 24: Calibration Step 3: Zero Calibration .....	37
Figure 25: Calibration Step 4: Weight Calibration .....	38
Figure 26: Calibration Step 5: Calibration Weight Value .....	39



Figure 27: Main Weight Display .....40

Figure 28: Tare Mode .....41

Figure 29: Tare Mode: Edit Tare .....42

Figure 30: Tare Mode: Edit Net .....43

Figure 31: System Info Menu .....45

Figure 32: Base Input Signal .....46

Figure 33: Max Gross .....47

Figure 34: Calibration Data .....48

Figure 35: Errors .....49

Figure 36: Software Version .....50

Figure 37: Serial Number .....51

# 1 Introduction

The AccuPro 1000 Digital Scale Controller is designed for use with Scaleton's complete line of cylinder, ton cylinder, drum, tank, platform, IBC tote, and spill containment scale bases. Engineered for ease of operation and intuitive performance, the controller features a high contrast graphic LCD display and a simple four button interface for quick navigation.

## 1.1 Scope

This operator's manual describes the specifications, assembly, and operation for the AccuPro 1000.

## 1.2 Acronyms and Abbreviations

- ***AWG*** American Wire Gauge
- ***CH*** Channel
- ***AC*** Alternating Current
- ***DC*** Direct Current
- ***V*** Volts
- ***A*** Amps
- ***mA*** Milliamps
- ***mV*** Millivolts
- ***W*** Watts
- ***ADC*** Analog to Digital Converter
- ***SG*** Specific Gravity
- ***ESD*** Electrostatic Discharge

### 1.3 Definitions

- **Channel:** A base that can be monitored by the system
- **Gross Weight:** The total weight (real weight) on the scale base. Determined by net weight plus (+) tare weight
- **Net Weight:** The weight of material without the presence of a tank or container. Determined by gross weight minus (-) tare weight
- **Tare:** A user-adjustable amount of weight subtracted from the gross weight to display the actual weight of material without the presence of a tank or container
- **Control Board:** The circuit board mounted on the back plate of the enclosure which houses all user connections.
- **Display Board:** The circuit board mounted on the door of the enclosure which houses the display.
- **Scale Base:** The physical platform where material is weighed and where the load cell(s) is/are located

### 1.4 Factory Options

- Dual-channel
- 4-20 mA analog output per channel (scale or loop powered)
- Remote mounting of enclosure up to 200 ft (61 m) away from scale base

## 2 Specifications

Main Power	<p><u>Supply Voltage:</u> 100 to 250 VAC, 50/60 Hz</p> <p><u>Max Wattage per Channel:</u> 3W</p> <p><u>Fuse:</u> 0.2A 5x20mm slow-blow (1 per control board)</p>
Operational Temperature	-17.8 °C to 54.4 °C (0 °F to 130 °F)
Operational Altitude	2000 m (6561 ft) (Max)
Operational Relative Humidity	20% to 90% non-condensing
Enclosure	<p><u>Nominal Size:</u> 8 x 8 x 4 Inches (LxWxD) with hinged cover</p> <p><u>Total Controller Weight:</u> 4 lbs (varies depending on configuration)</p> <p><u>Material:</u> Opaque Polycarbonate, UL Listed Type 4X NEMA</p> <p><u>Location Recommendation:</u> The enclosure should not be in an area with extreme weather conditions or heavy amounts of liquid soaking. If operating the system indoors, it is recommended to mount the enclosure in an area that protects against chemical splashes and wash-down areas, while still being easily accessible. If operating the system outdoors, it is recommended that a covering be used to protect the indicator from the elements.</p>
Channels	Supports single or dual-channel configuration. Each channel is independently controlled and operated.



## AccuPro 1000™ Operator's Manual

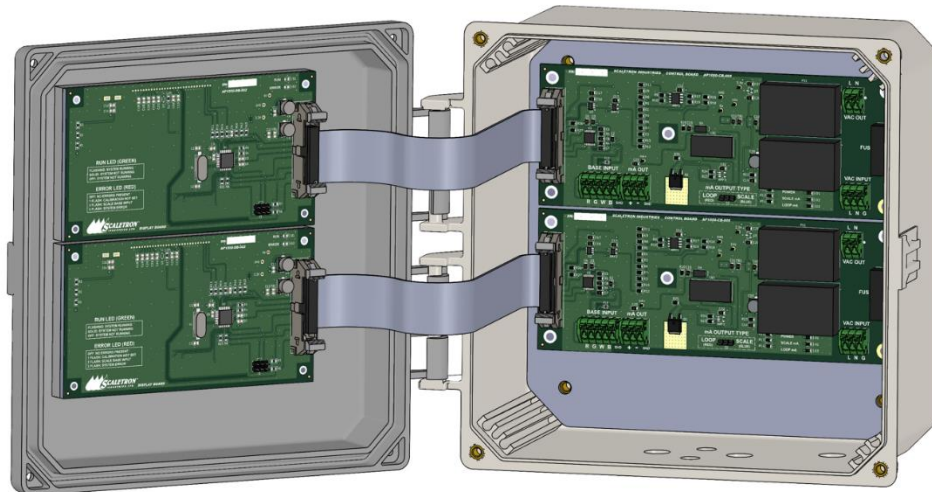
Measurement	<p><u>Display Range:</u> 6 digits (maximum) <u>Working Capacity:</u> determined, in part, by factory limits and scale base specifications. Reference scale base documentation. <u>Units:</u> user-defined units of lb, kg, gal, or L. <u>Performance:</u> 0.1% to 0.25% full scale accuracy.</p>
Display	<p>Size: 3.5" Width, 1.06" Height Type: Graphic LCD with backlight</p>
Controls	<p>Type: Push Buttons</p>
mA Output (factory option)	<p><u>Type:</u> Scale (self-powered) or Loop 12-30 VDC (loop-powered) <u>Maximum Load:</u> 500 Ohms</p>

## 3 Indicator Assembly and Configuration

This section provides detailed instructions for the mechanical mounting and electrical wiring of the AccuPro 1000. It covers enclosure preparation, user connections, and wiring. Proper adherence to these procedures is critical to ensure NEMA 4X sealing, electrical safety, and signal integrity.

**Internal Layout:** The enclosure houses all user connections and internal circuitry. While the example shown in this manual is a dual-channel indicator, the actual enclosure contents will vary based on your specific factory configuration.

- **Modular Architecture:** Each channel operates with its own dedicated control board (mounted to the back plate) and display board (mounted to the front door).
- **Connections:** A ribbon cable connects each control board to its corresponding display board.
- **Channel Orientation:** For dual-channel units, Ch 1 components are located in the top position, and Ch 2 components are located in the bottom position.



*Figure 1: Enclosure Contents*

### 3.1 Enclosure Preparation and Mounting

The enclosure is intended to be wall-mounted using the four holes in the corner flanges. It should be installed at operational level and positioned away from the floor to minimize risk of damage.

**Power Connection:** The enclosure is shipped with a factory-installed power cord utilizing a liquid-tight fitting. Do not modify the cord or restrict the ability to disconnect it from the outlet, as disconnection is required for safe service.

**Drilling and Sealing:** All other user connections must be made in the field. Take time to identify the optimal location for all additional fittings or conduit. Exercise extreme caution when drilling holes to avoid damaging internal components or cabling.

- All drilled holes must be sealed to prevent liquids and gases from penetrating the enclosure.
- It is recommended that all fittings be liquid-tight and NEMA 4X rated.
- If a fitting does not provide a tight seal, use silicone caulk to seal the opening and eliminate exposure.

**Internal Access and Safety:** Access to the internal components must be performed with care. Always disconnect power before making, modifying, or removing any wiring connections. Failure to remove power before adjusting terminal block connections can result in permanent damage to the circuit board or connected load cells.

- **Ribbon Cables:** When opening the enclosure for assembly or configuration, ensure that internal ribbon cables are not stressed, pinched, or disconnected.
- **ESD Precautions:** Take necessary precautions to prevent static discharge (ESD) when handling the exposed circuit boards.
- **Environmental Protection:** Do not leave the enclosure open in environments where moisture, conductive dust, or debris could enter the unit.

**Environmental Limitations:** Though the enclosure is NEMA 4X rated, it is not designed to withstand wash down procedures or chemical contact beyond accidental exposure. Avoid direct contact with chemicals or regular soaking of water, as this may cause substantial damage to the electronics. Any damage resulting from non-adherence to these requirements will not be considered for warranty repair.

### 3.2 Hardware Layout

The following figures illustrate the physical configuration of the AccuPro 1000, identifying key external features and internal electronic assemblies. Familiarize yourself with these component locations before performing installation or maintenance.

**External Interface:** The enclosure door houses the primary operator interface, including the high-contrast LCD screen and the four-key tactile keypad. The enclosure is designed for wall mounting or post mounting and utilizes a gasket seal to maintain NEMA 4X environmental protection.

**Internal Board Arrangement:** Internally, the indicator electronics are divided into two primary circuit boards connected by a ribbon cable:

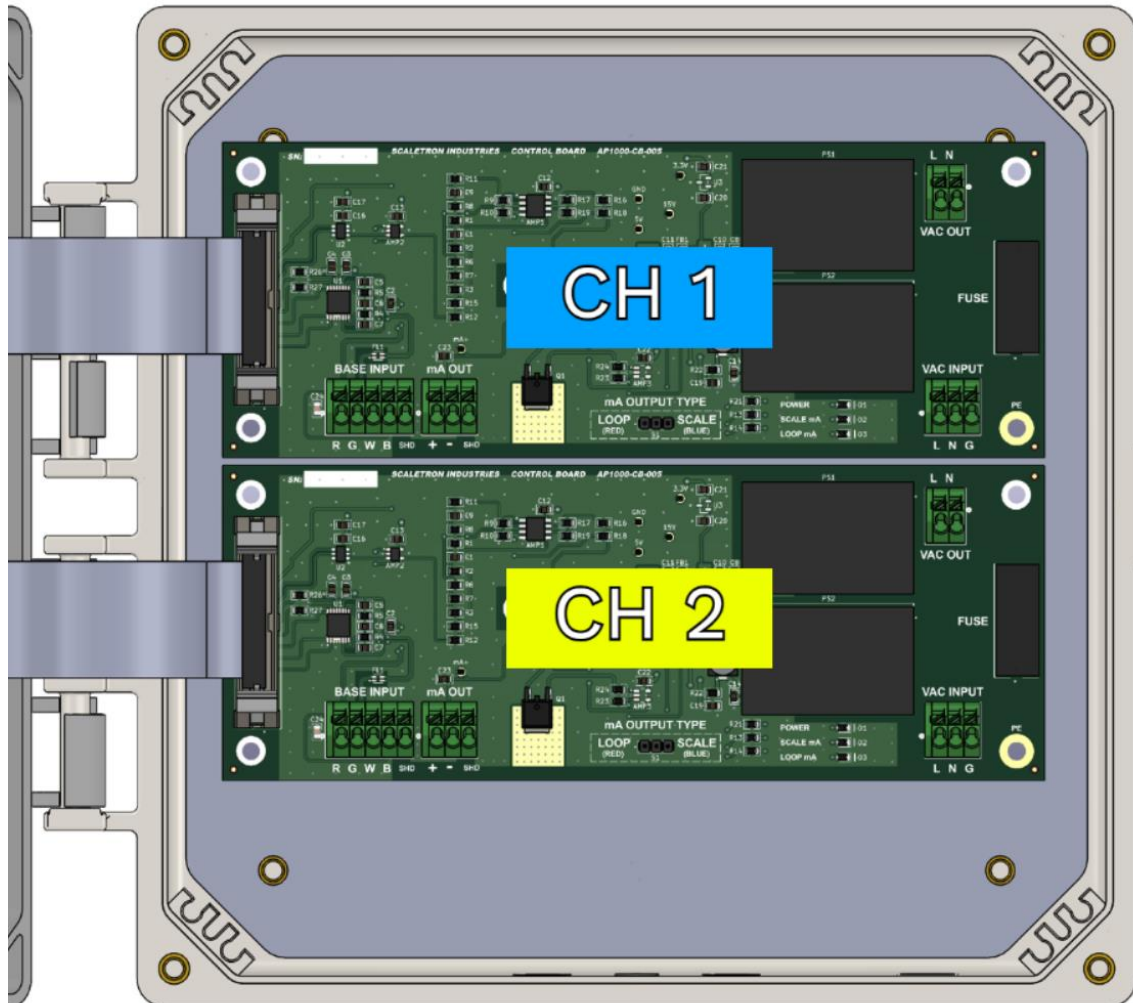
- **Control Board:** Mounted to the enclosure backplate, this board contains all user wiring connections, power input, mA output type selection, and status LEDs.
- **Display Board:** Mounted to the door of the enclosure, this board contains the main processor, display, and status LEDs.

**Multi-Channel Configuration:** For dual-channel units, independent board sets are installed for each channel. As shown in the internal views, Ch 1 components occupy the top position, and Ch 2 components occupy the bottom position.



**Figure 2: Indicator Front View**

Front view will vary depending on the number of channels configured. As shown is a dual-channel indicator.



**Figure 3: Control Board**

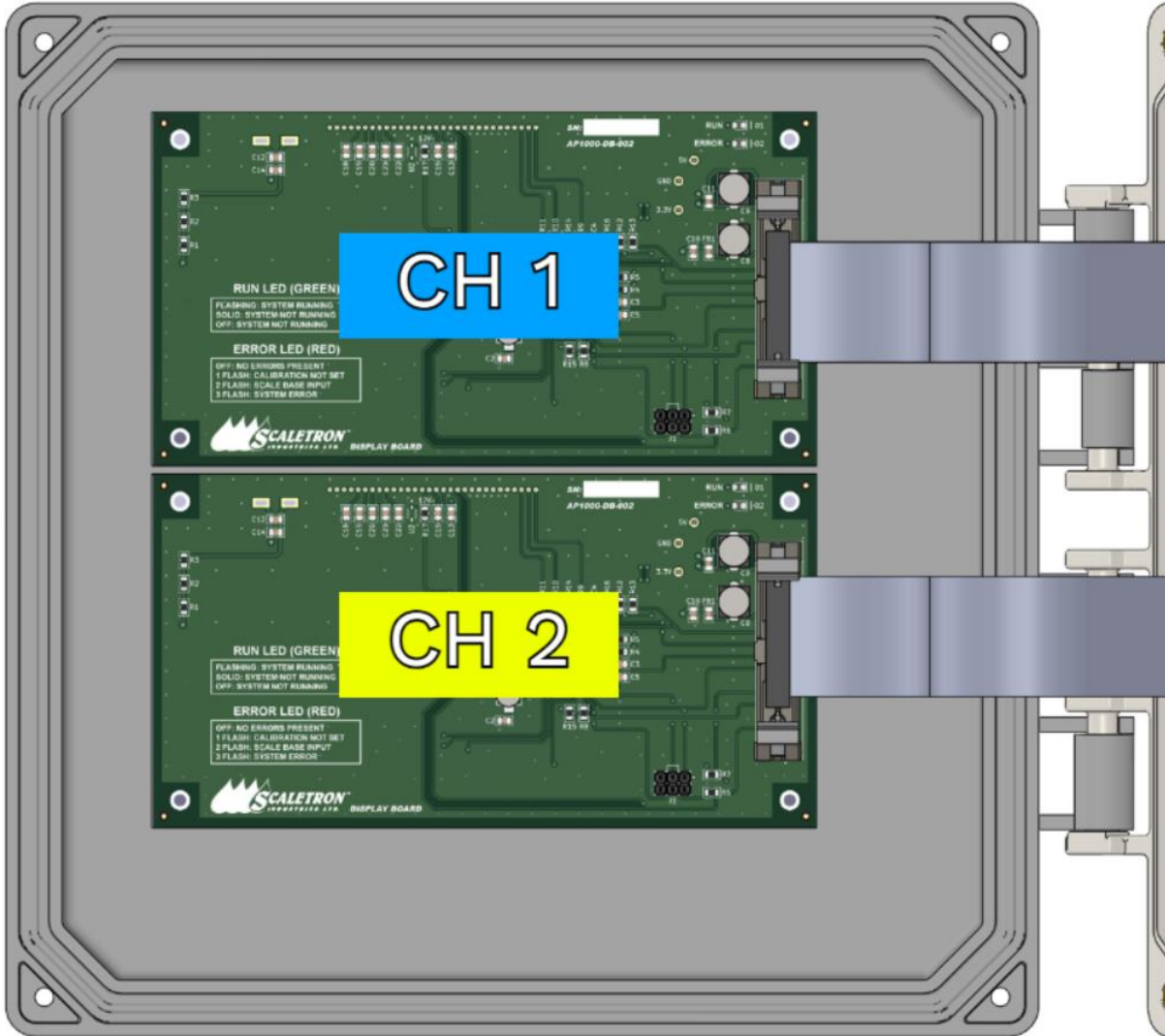
The control board contains all user wiring connections, power input, power input fuse, mA output type selector, and status LEDs. Ch 1 control board is mounted on the top (blue highlight), and Ch 2 control board is mounted on the bottom (yellow highlight).



**Figure 4: Control Board LEDs**

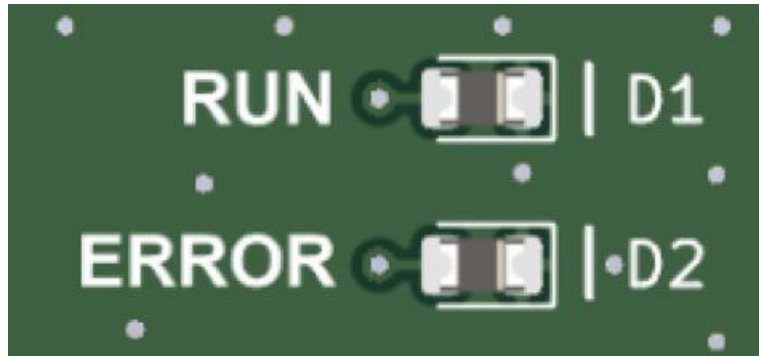
Each control board houses continuous status LEDs.

- POWER (Green): Indicates system power status.
- SCALE mA (Blue): Indicates mA type is configured for SCALE mode.
- LOOP mA (Red): Indicates mA type is configured for LOOP mode.



**Figure 5: Display Board**

The display board contains the main processor, display, and status LEDs. Ch 1 display board is mounted on the top (blue highlight), and Ch 2 display board is mounted on the bottom (yellow highlight).



**Figure 6: Display Board LEDs**

Each display board houses flashing status LEDs.

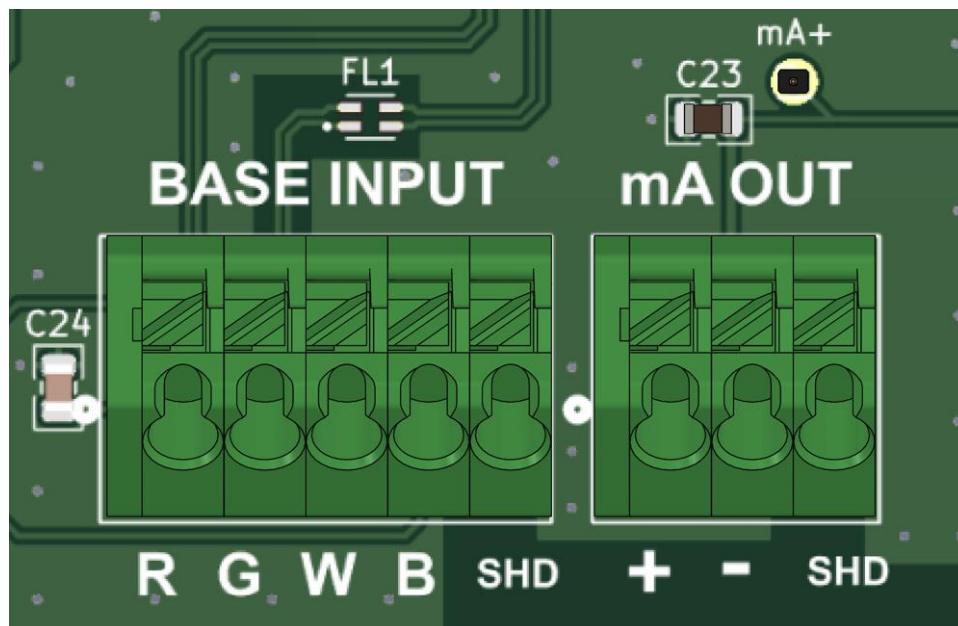
- RUN (Green):
  - Flashing: System is running
  - Solid: System is not running
  - Off: System is not running
- ERROR: (Red):
  - Off: No errors are present
  - 1 Flash: Calibration is not set
  - 2 Flash: Scale base input error detected
  - 3 Flash: Critical system hardware fault detected

**Note:** See section 9 for more information on errors and troubleshooting

### 3.3 Scale Base Input Wiring

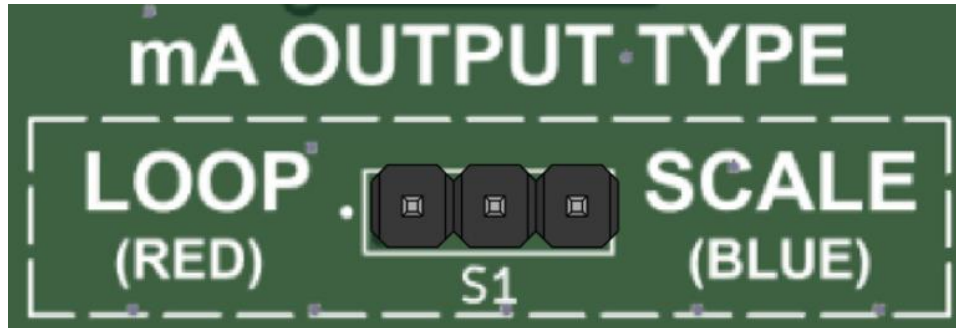
The scale base connects to the 5-position terminal block labeled BASE INPUT located on the bottom edge of the control board. The terminal positions are labeled R, G, W, B, and SHD to match standard scale base input cable wire coloring. The cable is provided with pre-stripped wires to facilitate quick and secure termination.

- **Channel Identification:** For dual-channel indicators, identify the correct control board to connect to. Connect cable with blue heat shrink to Ch 1 control board (mounted on top). Connect cable with yellow heat shrink to Ch 2 control board (mounted on bottom).
- **Wiring Connection:** Push down on the spring terminal and insert the wires into the location, matching the wire colors to the label: Red to R, Green to G, White to W, Black to B, and shield to SHD. Gently tug on each wiring connection to ensure a secure connection.



*Figure 7: Scale Base Input Wiring Connection*

### 3.4 mA Output Type Selection



**Figure 8: mA Output Type Selection**

The 4-20 mA analog output can be configured for either SCALE (self-powered) or LOOP (loop-powered) operation using the selector jumper located on the control board. This setting determines whether the current loop is powered by the indicator itself or by an external power supply.

**SCALE mA Output (Blue status LED):** In this mode, the mA output is self-powered for direct meter connection to the mA output. View section 3.5 for wiring information.

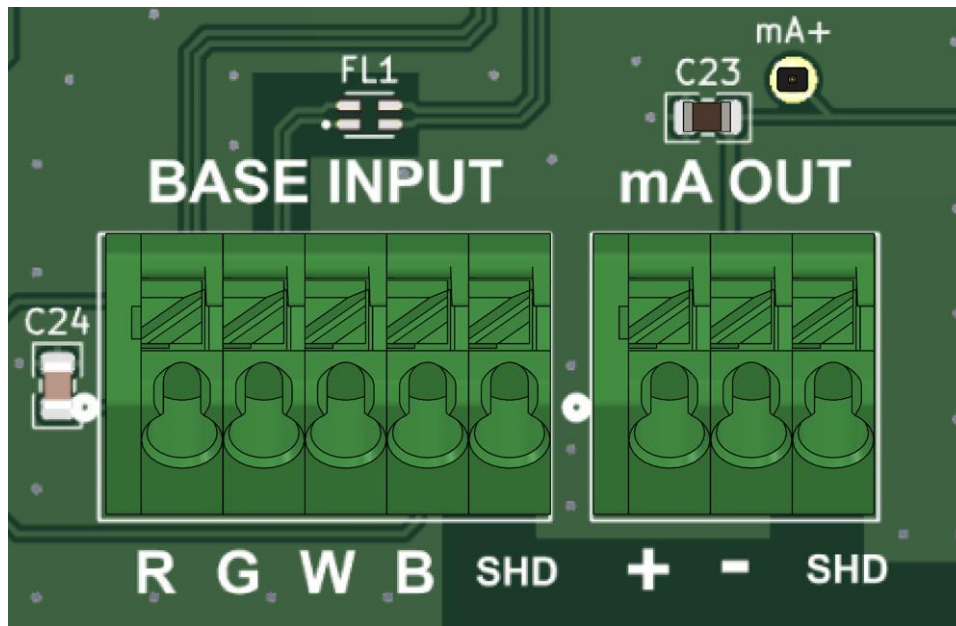
**LOOP mA Output (Red status LED):** In this mode, the mA output requires an external power supply to drive the current. View section 3.5 for wiring information.

**WARNING:** Verify the jumper position before applying power. Configuring the output for SCALE type while connecting it to a power supply may result in voltage conflict and permanent damage to the mA output.

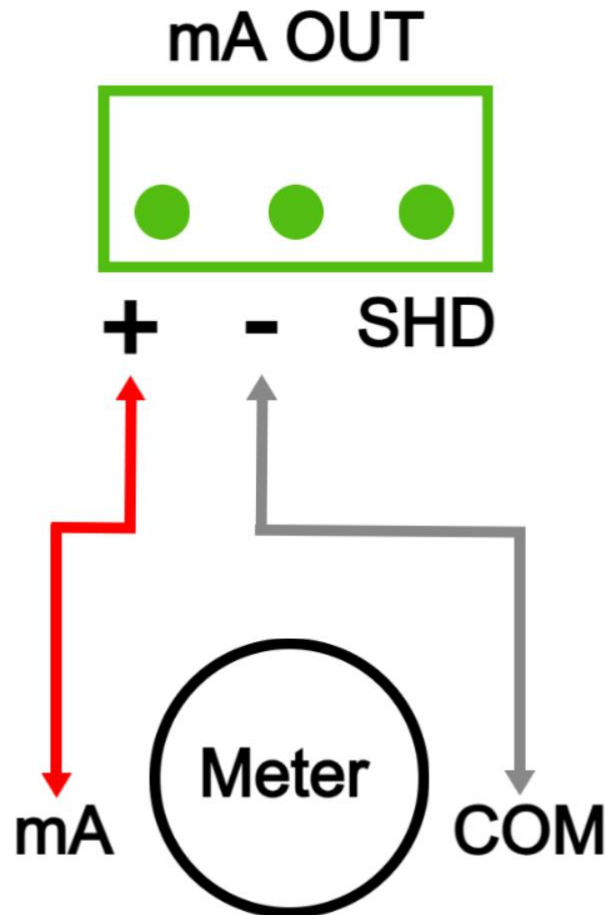
### 3.5 mA Output Wiring

To access the 4-20 mA output, connect to the 3-position terminal block labeled mA OUT located on the bottom edge of the control board. The terminal positions are labeled +, -, and SHD. This output terminal block supports both SCALE (self-powered) and LOOP (loop-powered) type depending on the jumper setting.

- **Channel Identification:** For dual-channel indicators, identify the correct control board to connect to. The Ch 1 control board is mounted on the top, and the Ch 2 control board is mounted on the bottom.
- **Wiring Connection:** Push down on the spring terminal and insert the wires into the location, matching the signal polarity to the label: signal positive to +, signal COM to -, and shield to SHD. **For detailed wiring information, view figures 10 and 11.** Gently tug on each wiring connection to ensure a secure connection.

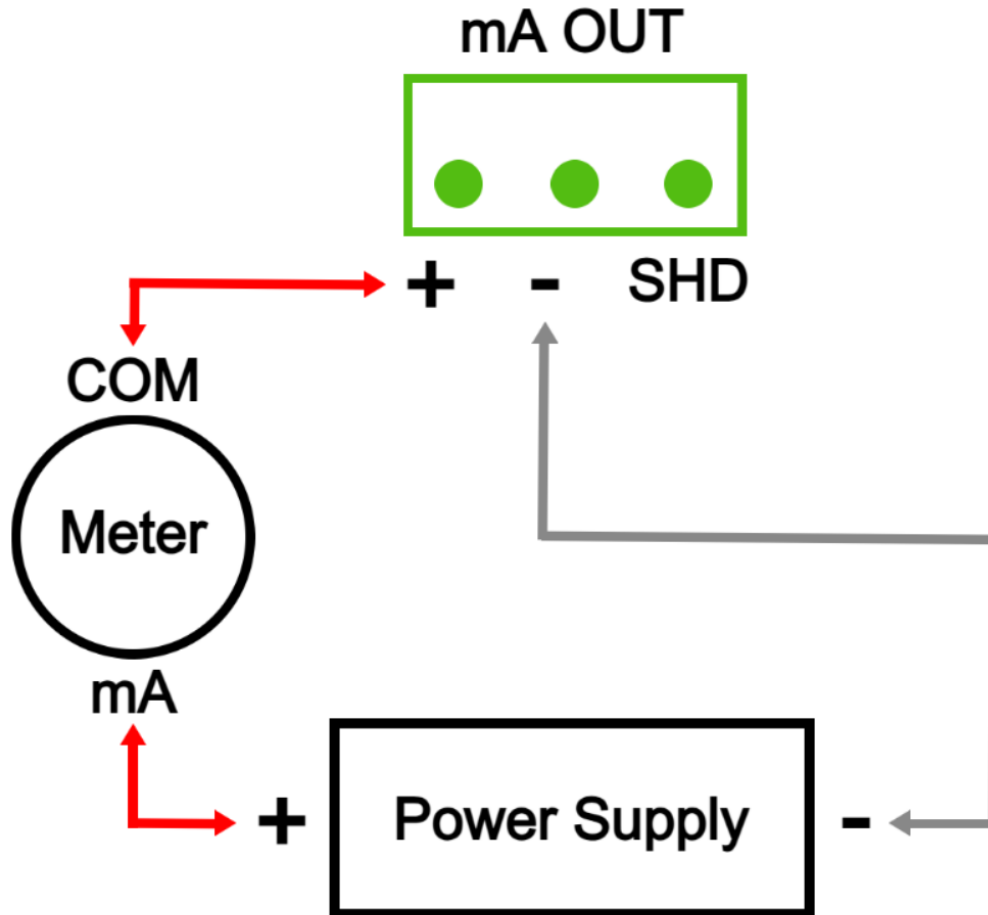


*Figure 9: mA Output Wiring Connection*



**Figure 10: Scale (Self-Powered) mA Output Wiring Diagram**

To be used when mA OUTPUT TYPE jumper is configured in SCALE (self-powered) mode. Connect cable shield wire to SHD connection.



**Figure 11: Loop (Loop-Powered) mA Output Wiring Diagram**

To be used when mA OUTPUT TYPE jumper is configured in LOOP (loop-powered) mode. Connect cable shield wire to SHD connection.

**Note:** Loop power supply must be in the range of 12-30 VDC with a maximum load of 500 ohms.

## 4 System Operation and Navigation

The AccuPro 1000 can contain up to 2 channels. Each channel is independently controlled and operated. The AccuPro 1000 is designed for intuitive operation using a simple four-button interface. The system structure is divided into three primary operating modes:

- **Main Weight Display:** The default state showing the main weight display.
- **Configuration Menus:** Used for system setup, parameter changes, and calibration.
- **System Info Menus:** Used for viewing diagnostics and system information.

### 4.1 Startup Sequence

Upon applying power, the indicator displays information on 3-second long splash screens, followed by the main weight display.

#### Power-On Splash Screens:

1. Indicator model and serial number
2. Max gross

#### Default Screen After Initial Splash Screens:

1. Main weight display

### 4.2 Button Functions and Layout

The interface utilizes four buttons (↑), (→), (TARE/ENTER), and (CONFIG). Each button function depends on the screen being displayed.

**Access Config Menu:** While on the main weight display, momentarily press the (CONFIG) button.

**Access System Info:** From any screen, press and hold the (CONFIG) button.

**Access Tare Options:** While on the main weight display, momentarily press the (TARE/ENTER) button.

**Config/System Info Menu Navigation:** Scroll up using the (↑) button and go to the menu option by pressing the (TARE/ENTER) button.

**Configuration Option Adjustment:** Choose the selection by using the (→) button. The selected option will be highlighted.

**Value Adjustment:** Select digit using (→) button, increment digit using (↑) button. The selected digit will have a flashing underline.

**Save/Exit operation:** While in any system menu or configuration screen the (TARE/ENTER) button acts as a (SAVE) button, while the (CONFIG) button acts as a (BACK/EXIT) button.

## 5 Configuration Menu

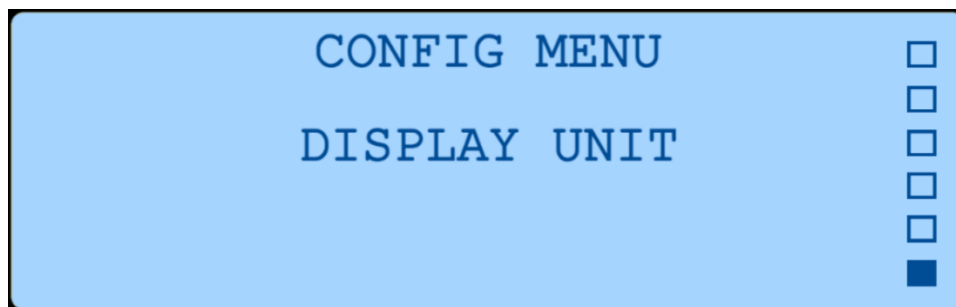
The configuration menu is used for adjusting system settings. The user can access the configuration menu by momentarily pressing the (CONFIG) button while on the main weight display screen. The scroll bar on the right side of the configuration menu indicates available menu options. To scroll through the configuration menu use the (↑) button. To enter a menu option, press the (TARE/ENTER) button while on the desired selection.

### Configuration Menu Options:

- DISPLAY UNIT
- DISPLAY DECIMAL
- WEIGHT STABILITY
- 4-20 mA OUTPUT
- SPECIFIC GRAVITY
- CALIBRATION

**Note:** 4-20 mA OUTPUT is a factory option. Depending on indicator configuration from factory, this option may not be visible in the configuration menu.

**Note:** Calibration is pre-set from factory and password protected for security.



*Figure 12: Configuration Menu*

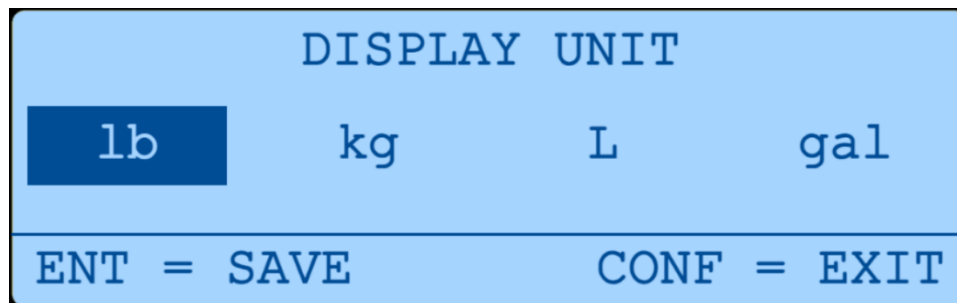
## 5.1 Display Unit

The user can adjust the display unit for the system. The display unit applies to all weight value parameters: display net or gross, TARE, 20 mA VALUE, and MAX GROSS

### Display Unit Options:

- **lb (pounds)**
- **kg (kilograms)**
- **L (liters)**
- **gal (gallons)**

**Note:** Liters and gallons are calculated based on the specific gravity setting. If selecting a volume unit, ensure the specific gravity is set correctly for your product.



*Figure 13: Display Unit*

## 5.2 Display Decimal

The user can adjust the display decimal for the system. The display decimal applies to all weight value parameters: display net or gross, TARE, and 20 mA VALUE.

### Display Decimal Options:

1. 0 (Example: 100 lb)
2. 1 (Example: 100.0 lb)

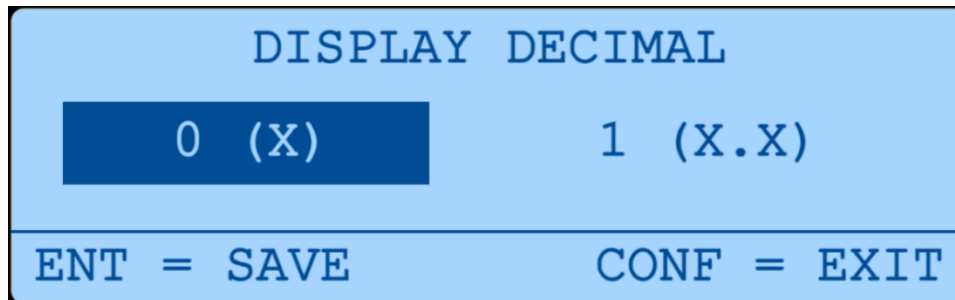


Figure 14: Display Decimal

### 5.3 Weight Stability

This setting controls the digital filtering applied to the scale base input signal. It allows the user to optimize the balance between response speed and instability/vibration rejection.

#### Weight Stability Options:

**1. Standard:**

- Recommended Use Case: General purpose weighing applications
- Performance: Provides a stable reading with a fast response time.

**2. High:**

- Recommended Use Case: When the standard option results in the weight display jumping or fluctuating due to liquid sloshing, heavy vibration, etc.
- Performance: This mode applies a large amount of filtering to keep the weight display steady. The weight display will update slower and react slower to changes in weight.

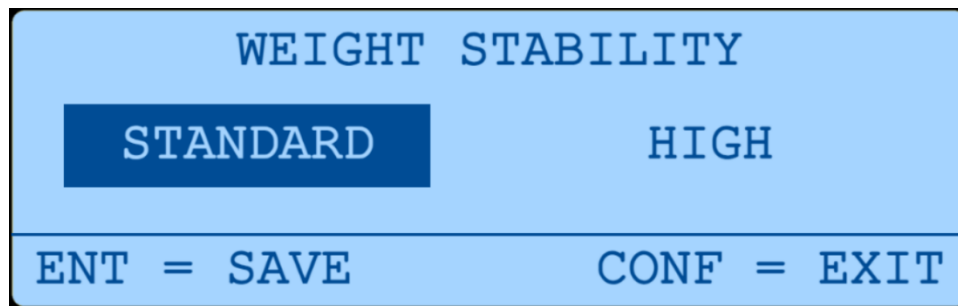


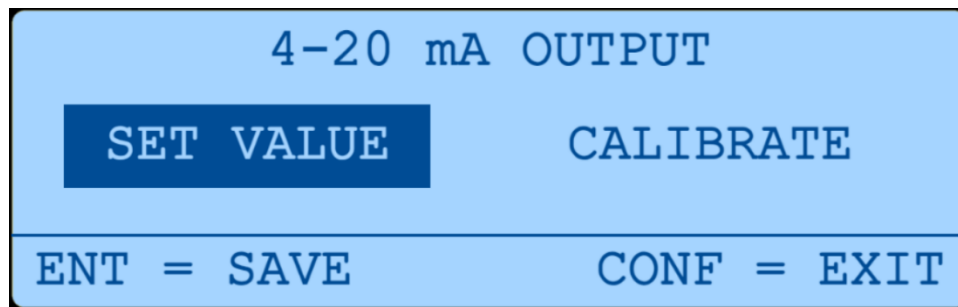
Figure 15: Weight Stability

## 5.4 4-20 mA Output

This setting allows the user to configure the 4-20 mA output signal. The 4-20 mA output is scaled based on net weight: 0 weight outputs 4 mA, and the user-defined 20 mA VALUE outputs 20 mA. To configure SCALE (self-powered) or LOOP (loop-powered) type, view section 3.4.

### 4-20 mA Output Options:

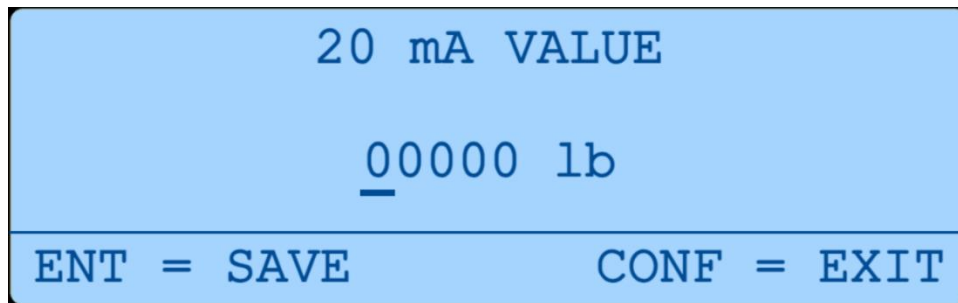
- 1. Set Value:**
  - Defines the mA output scaling.
- 2. Calibrate:**
  - Used to digitally trim the output signal to ensure accuracy.



*Figure 16: 4-20 mA Output*

**20 mA Value:**

- Function: Defines the mA output scaling.
- Example: If the 20 mA VALUE is set to 1000 lbs, then 0 lbs = 4 mA, and 1000 lbs = 20 mA. Any net weight value in between these points scales proportionally (500 lbs would output 12 mA).



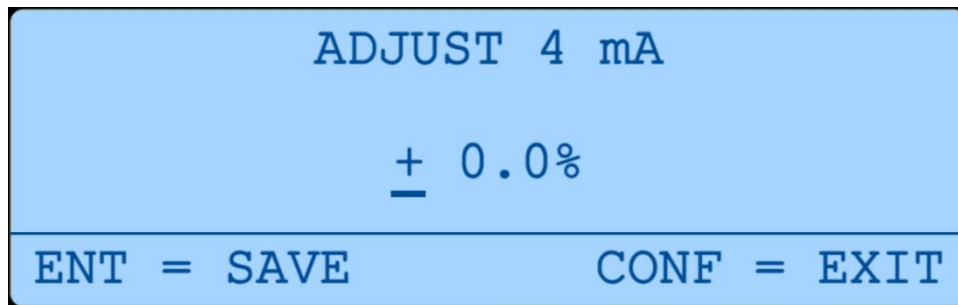
*Figure 17: 20 mA Value*

**Adjust 4 mA:**

This feature is used to digitally trim the minimum mA signal to ensure accuracy, and should be performed only if there is a discrepancy between the displayed mA output and your external meter (example: your meter reads 4.1 mA while the controller displays 4.0 mA).

**Adjustment Procedure:**

- 1. Measure:** While accessing this screen, the controller automatically outputs a 4 mA signal. Connect a multimeter, PLC, or some other mA measuring device to monitor the 4 mA output signal.
  - **If meter reads 4.00 mA:** The output is accurate. Press the (TARE/ENTER) button immediately to save and skip to the next step.
  - **If meter reads incorrectly (example: 4.1 mA):** Proceed to step 2.
- 2. Adjust Value:** Adjust the +/- trim percentage until the external measurement device reads as close as possible to 4.0 mA
- 3. Save:** To save 4 mA calibration, press (TARE/ENTER) button. The system will automatically advance to the Adjust 20 mA screen.



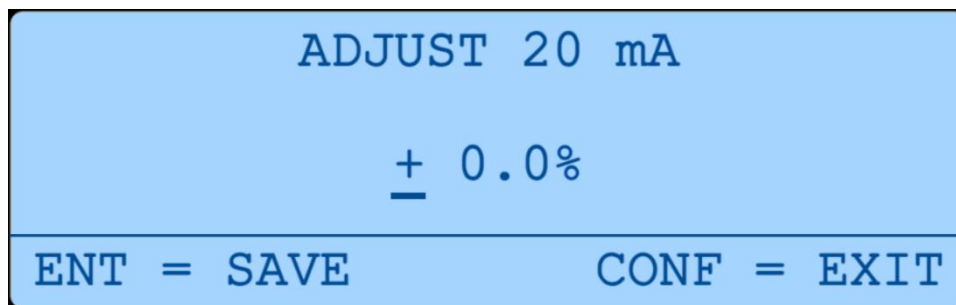
*Figure 18: Adjust 4 mA Trim*

## Adjust 20 mA:

This feature is used to digitally trim the maximum mA signal to ensure accuracy, and should be performed only if there is a discrepancy between the displayed mA output and your external meter (example: your meter reads 19.9 mA while the controller displays 20.0 mA).

### Adjustment Procedure:

- 1. Measure:** While accessing this screen, the controller automatically outputs a 20 mA signal. Connect a multimeter, PLC, or some other mA measuring device to monitor the 20 mA output signal.
  - **If meter reads 20.00 mA:** The output is accurate. Press the (TARE/ENTER) button immediately to save.
  - **If meter reads incorrectly (example: 19.9 mA):** Proceed to step 2.
- 2. Adjust Value:** Adjust the +/- trim percentage until the external measurement device reads as close as possible to 20.0 mA
- 3. Save:** To save 20 mA calibration, press (TARE/ENTER) button. The system will automatically exit to the 4-20 mA Output screen.



*Figure 19: Adjust 20 mA Trim*

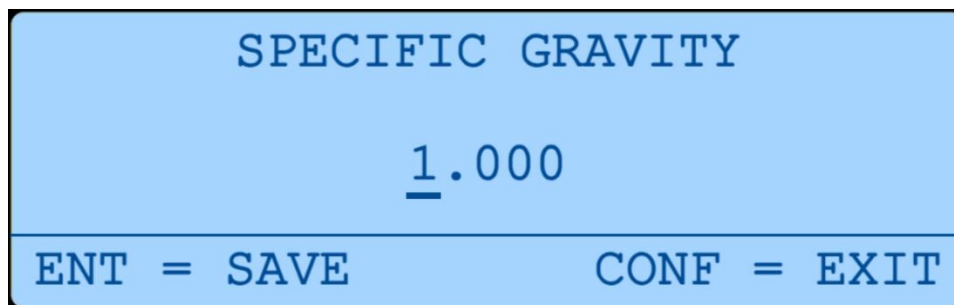
## 5.5 Specific Gravity

This setting defines the density of the product relative to water. It is required to accurately calculate volume when the display unit is set to liters (L) or gallons (gal). The system measures the weight of the product and uses the specific gravity value to convert that weight into a volume reading.

- **Default Value: 1.000** (pure water).
- **When to Adjust:** Adjust this value only if you are measuring a liquid that is lighter or heavier than water (example: Diesel = ~0.850, Heavy Syrup = ~1.300) and require a readout in Liters or Gallons.
- **Note:** This parameter is ignored if the display unit is set to weigh in lb or kg.

**Example Calculation (for 1000 lbs of product):** Since volume depends on density, the same 1000 lb weight will display different volumes based on the SG setting:

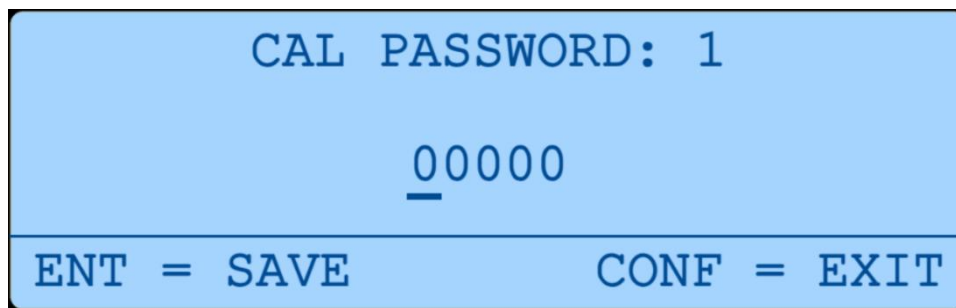
- **SG = 1.000 (Water):** Display reads approx. 120 gal.
- **SG = 0.500 (Light Liquid):** Display reads approx. 240 gal. (Lighter liquid takes up more space for the same weight).
- **SG = 2.000 (Heavy Liquid):** Display reads approx. 60 gal. (Heavier liquid takes up less space for the same weight).



*Figure 20: Specific Gravity*

## 5.6 Calibration

The AccuPro 1000 is fully calibrated at the factory to its matching scale base (verified by serial number) and is ready for immediate use. Field recalibration should not be performed unless absolutely required by a specific maintenance protocol or weighing error. To prevent accidental changes to critical calibration data, this menu is protected by a security password. To perform a recalibration, you must contact Scaleton Industries. If recalibration is deemed appropriate for the circumstance, technical support will provide the password required to enter this menu.



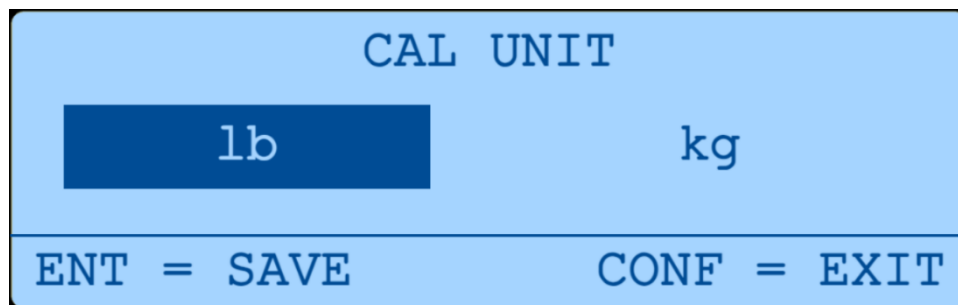
*Figure 21: Calibration Password*

### Calibration Step 1: Calibration Unit

This setting defines the unit of measure for the calibration process. You must select the unit that matches the known weight you will use to calibrate the scale.

#### Options:

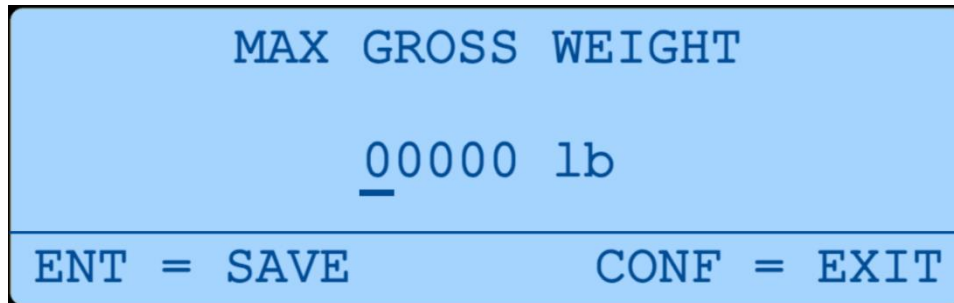
1. lb (pounds)
2. kg (kilograms)



*Figure 22: Calibration Step 1: Calibration Unit*

**Calibration Step 2: Max Gross Weight**

This step defines the maximum rated capacity of the scale base, establishing the 100% full-scale limit of the system. Enter the full capacity value exactly as listed on the scale's nameplate or datasheet. The controller uses this setting to safeguard the process by detecting overloads and rejecting any Tare entries that exceed the scale's physical capacity.



*Figure 23: Calibration Step 2: Max Gross Weight*

## Calibration Step 3: Zero Calibration

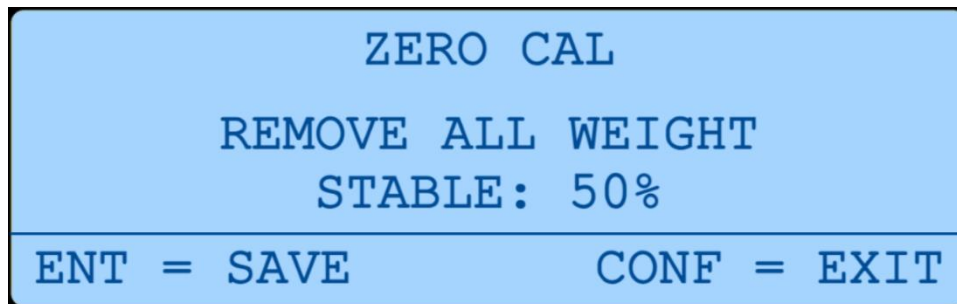
This step measures the dead load of the empty scale base to establish a true zero reference.

### Procedure:

- **1. Clear the Scale:** Ensure the scale base is completely free of any weight, debris, tools, etc.
- **2. Monitor Stability:** The controller will begin monitoring the base input signal for stability. You will see a percentage indicator (example: STABLE: 50%) counting up on the display.
  - **Note:** If the scale base is detected to be unstable during this time, the stability check percentage will reset.
- **3. Wait for Prompt:** Once the signal has remained stable for the full stability check duration, the screen will display PRESS ENTER.
- **4. Capture Zero Calibration:** Press the (TARE/ENTER) button to capture the zero calibration and automatically advance to the next calibration step.

**Testing Bypass:** For troubleshooting purposes only, you may force a zero calibration even if the stability check is not complete. To do this, press and hold the (TARE/ENTER) button for 2 seconds to bypass the timer.

- **Warning:** Bypassing the stability check may result in an inaccurate calibration.



*Figure 24: Calibration Step 3: Zero Calibration*

## Calibration Step 4: Weight Calibration

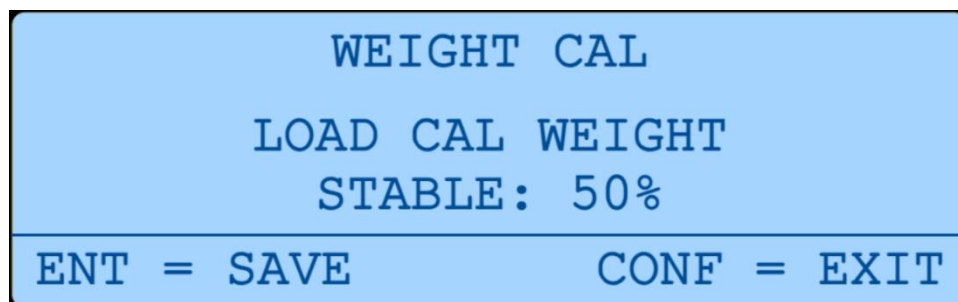
This step measures the base input signal generated by the calibration weight to establish the linear calibration reference.

### Procedure:

- **1. Load the Scale:** Place your known calibration weight onto the scale base. A calibration weight of 50-100% max gross weight is recommended for best accuracy.
- **2. Monitor Stability:** The controller will begin monitoring the base input signal for stability. You will see a percentage indicator (example: STABLE: 50%) counting up on the display.
  - **Note:** If the scale base is detected to be unstable during this time, the stability check percentage will reset.
- **3. Wait for Prompt:** Once the signal has remained stable for the full stability check duration, the screen will display PRESS ENTER.
- **4. Capture Weight Calibration:** Press the (TARE/ENTER) button to capture the weight calibration and automatically advance to the next calibration step.
  - **Note:** Weight calibration signal must be greater than zero calibration signal to avoid calibration error messages.

**Testing Bypass:** For troubleshooting purposes only, you may force a weight calibration even if the stability check is not complete. To do this, press and hold the (TARE/ENTER) button for 2 seconds to bypass the timer.

- **Warning:** Bypassing the stability check may result in an inaccurate calibration.

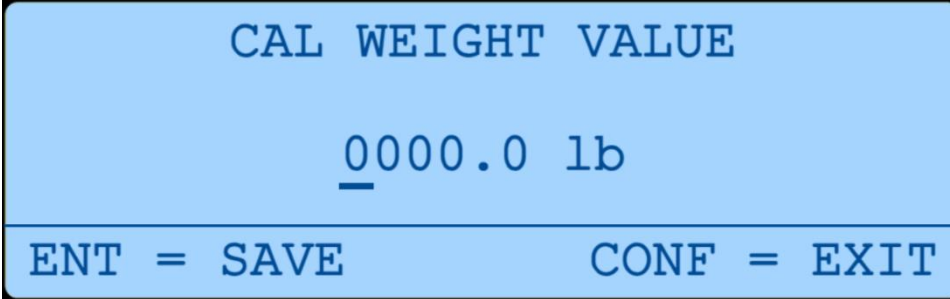


*Figure 25: Calibration Step 4: Weight Calibration*

**Calibration Step 5: Calibration Weight Value**

This step defines the actual weight value corresponding to the signal captured in the previous step. Enter the exact value of the weight used during the weight calibration. This entry establishes the span reference, allowing the controller to calculate the precise linear slope between the zero point and the loaded weight.

**Note:** This is the final calibration step.



```

CAL WEIGHT VALUE
      0000.0 lb
      0
ENT = SAVE          CONF = EXIT

```

*Figure 26: Calibration Step 5: Calibration Weight Value*

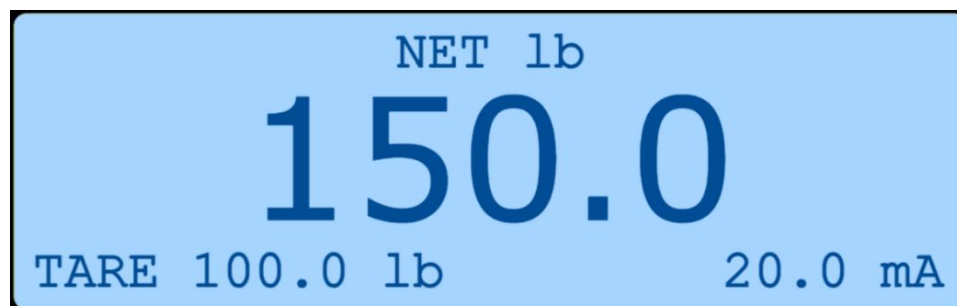
## 6 Weight Display

The AccuPro 1000 main weight display features a large font weight value, unit designator, error status, tare, mA output, and overload indicator. Display settings can be changed in configuration.

1. **Title:** Indicates the current weighing mode and display unit, or error status.
  - **GROSS or NET:** Depending on if any tare is active.
  - **lb, kg, L, gal:** Depending on unit selection.
  - **Error Messages:** Flashes error description if an error is active.
2. **Primary Weight Display Area (Center):** The current weight value is displayed in large, bold digits in the center of the screen.
  - **Overload Indication:** If the weight exceeds the calibrated max gross capacity, the weight digits will blink to alert the operator.
3. **Info Line (Bottom Area):** Displays secondary information based on configuration.

**Note:** The mA Output will only be visible if indicator is configured with factory option 4-20 mA output.

- **TARE:** Displays active tare value.
- **mA:** Displays current mA output signal.



*Figure 27: Main Weight Display*

## 7 Tare Adjustment

The tare function allows the user to subtract the weight of a tank, cylinder, or any other type of containment vessel so that the display shows only the weight of the product (net weight). To access the tare menu, momentarily press the (TARE/ENTER) button while on the main weight display.

The AccuPro 1000 provides two methods of tare adjustment to enhance flexibility.

- **EDIT TARE:** Enter the known containment vessel weight.
- **EDIT NET:** Enter the known product weight to automatically calculate tare.

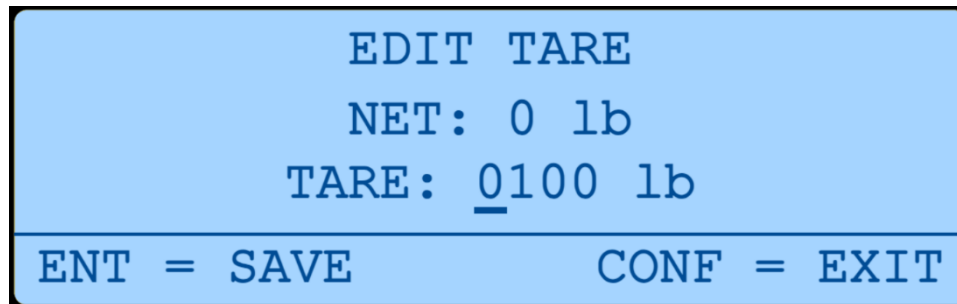


*Figure 28: Tare Mode*

## 7.1 Tare Mode: Edit Tare

Use this mode when you know the exact weight of the containment vessel.

1. From the Tare Menu, use the (→) button to select “EDIT TARE” and press (TARE/ENTER).
  - Top Line “NET”: Displays the live net weight (current gross minus the tare you are currently editing).
  - Bottom Line “TARE”: Displays the editable tare value.
2. Enter the weight of your containment vessel. As you change the tare value, the net value on the top line will update in real time.
3. Press (TARE/ENTER) to save tare or (CONFIG) to exit without saving.

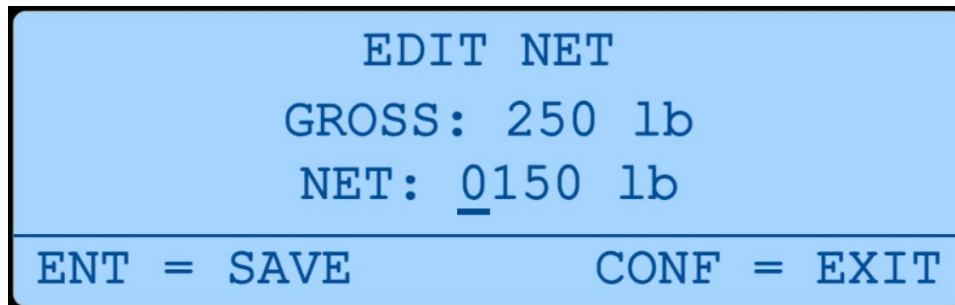


*Figure 29: Tare Mode: Edit Tare*

## 7.2 Tare Mode: Edit Net

Use this mode when you know the exact weight of the product in the containment vessel.

1. From the Tare Menu, use the (→) button to select “EDIT NET” and press (TARE/ENTER).
  - Top Line “GROSS”: Displays the live gross weight currently on the scale base
  - Bottom Line “NET”: Displays the editable net weight value.
2. Enter the weight of your product. The system will automatically calculate the tare value from the entered net value and current gross weight.
3. Press (TARE/ENTER) to save tare or (CONFIG) to exit without saving.



*Figure 30: Tare Mode: Edit Net*

### 7.3 Tare Errors

The system prevents invalid tare operations to ensure weighing accuracy. If an invalid entry is attempted, the screen will display “TARE ERROR” followed by the specific reason:

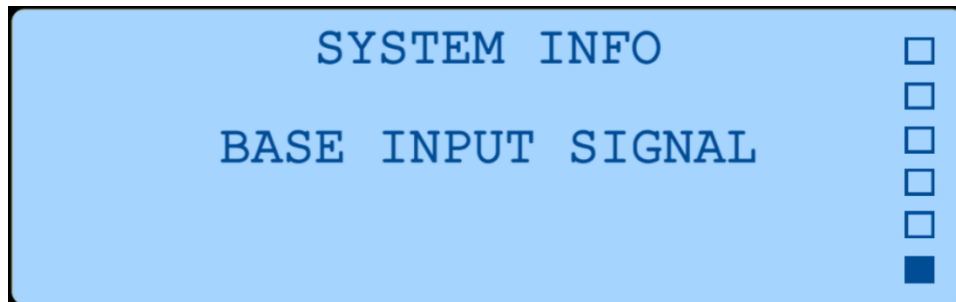
- **NET > GROSS:** Occurs in EDIT NET mode if you enter a net weight that is higher than the current gross weight.
- **TARE > MAX GROSS:** Occurs if the tare value entered (or calculated) exceeds the maximum capacity of the scale.
- **GROSS < 0:** You cannot access EDIT NET mode if gross weight is below 0.
- **NOT CALIBRATED:** Tare functions are disabled if the system has not been calibrated.

## 8 System Info Menu

The system info menu is a read-only menu used for diagnostics and troubleshooting. The user can access the system info menu by pressing and holding the (CONFIG) button while on any screen. The scroll bar on the right side of the system info menu indicates available menu options. To scroll through the configuration menu use the (↑) button. To enter a menu option, press the (TARE/ENTER) button while on the desired selection.

### System Info Menu Options:

- **BASE INPUT SIGNAL**
- **MAX GROSS**
- **CALIBRATION DATA**
- **ERRORS**
- **SOFTWARE VERSION**
- **SERIAL NUMBER**



*Figure 31: System Info Menu*

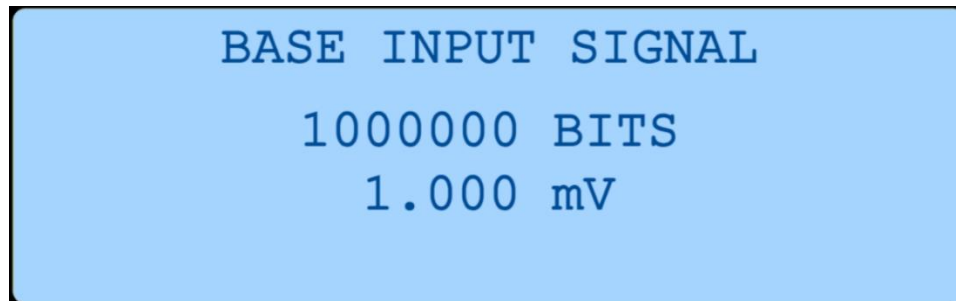
## 8.1 Base Input Signal

This screen displays the real-time signal received from the scale base. It provides two values: the filtered analog-to-digital (ADC) count (labeled as BITS), and the calculated signal voltage between the signal wires (green + and white -) in millivolts (mV).

**Usage:** This is the primary diagnostic tool for verifying scale base and wiring status.

**Verification:**

- When the scale base is stable, these values should be stable.
- When weight is applied to the scale, these numbers should increase.
- When weight is removed from the scale, these numbers should decrease.
- General Rule (can vary depending on scale base): The mV value with all weight removed should be close to 0 mV, while the mV value with max capacity weight loaded should be close to 5-10 mV.



*Figure 32: Base Input Signal*

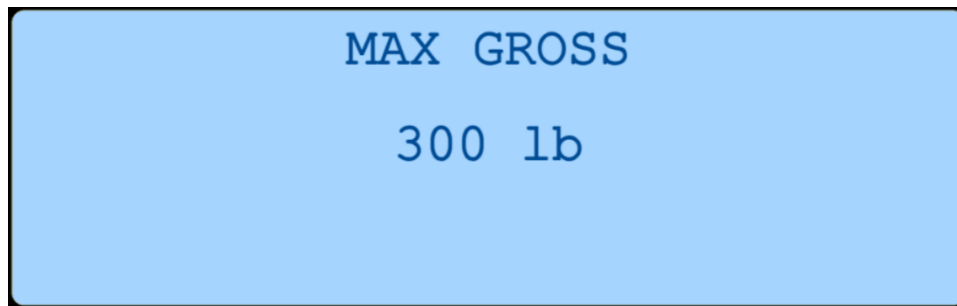
## 8.2 Max Gross

This screen displays the maximum rated capacity of the scale base. This value corresponds to the MAX GROSS WEIGHT value entered during the calibration process.

**Usage:** This serves as a reference of the maximum weight that can be loaded onto the scale base and to confirm the indicator is configured for the correct scale base capacity.

**Verification:**

- This value should match the full capacity rating of the scale base.
- This value establishes the 100% full scale limit used for overload protection.
- If the screen displays “NOT SET”, the indicator has not been calibrated.



*Figure 33: Max Gross*

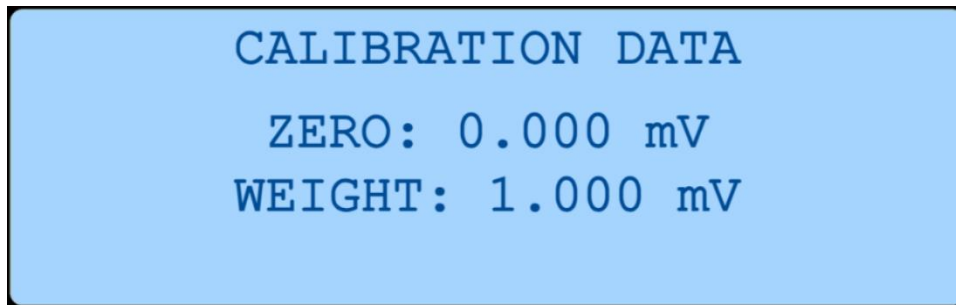
### 8.3 Calibration Data

This screen displays the stored signal mV values captured during calibration currently being used. It provides two reference points: ZERO, which is the signal that was measured during the zero calibration, and WEIGHT, which is the signal that was measured during the weight calibration.

**Usage:** This is a diagnostic tool for viewing the stored reference points during zero and weight calibration.

**Verification:**

- **Span Check:** The difference between these two values represents the linear calibration span. If both values are 0.000 mV, the calibration is invalid or has not been performed.



*Figure 34: Calibration Data*

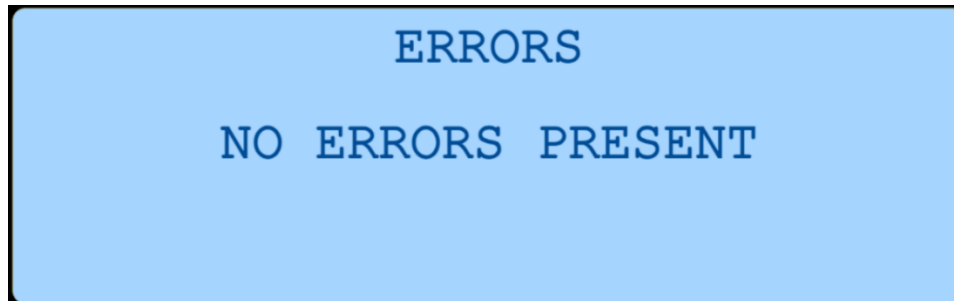
## 8.4 Errors

This screen displays the current health status of the indicator.

**Usage:** This screen is used to view any active errors within the system.

**Verification:**

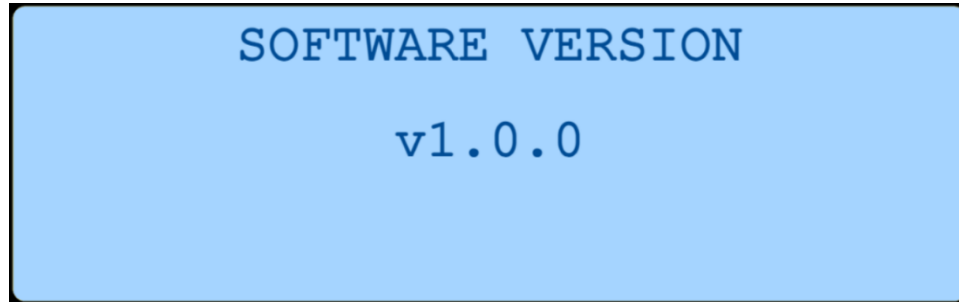
- **“NO ERRORS PRESENT”:** The system is functioning normally.
- **“BASE INPUT ERROR”:** The indicator detects a problem with the scale base input signal. This usually indicates the scale base is disconnected, the scale base cable is cut, or the signal is physically out of range (overload/underload) which indicates an issue with the scale base load cells.
- **“CALIBRATION NOT SET”:** The unit has not been calibrated, or the calibration data has been corrupted. The unit will not weigh until a valid calibration is performed.
- **“SYSTEM ERROR”:** This typically indicates an internal hardware failure requiring service.



*Figure 35: Errors*

## 8.5 Software Version

This screen displays the software version of the indicator.



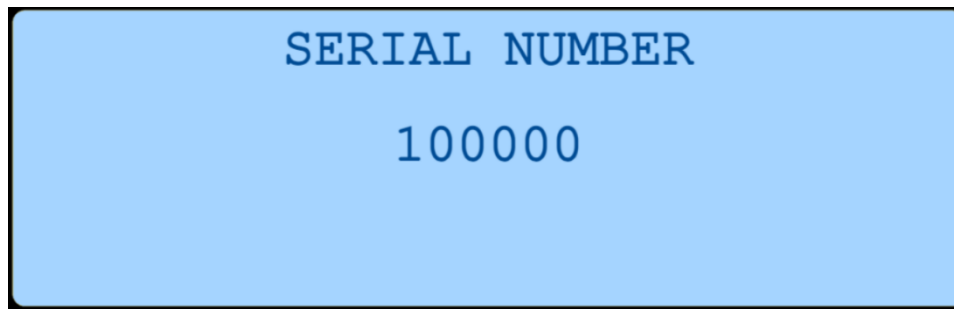
*Figure 36: Software Version*

## 8.6 Serial Number

This screen displays the serial number of the indicator.

### Verification:

- Ensure indicator and scale base serial numbers match each other. Each indicator is calibrated to the scale base with its corresponding serial number.



*Figure 37: Serial Number*

## 9 Errors and Troubleshooting

This section provides a comprehensive guide to understanding the various messages, alerts, and behaviors of the AccuPro 1000. It covers critical system errors indicated by the status LED, operational messages that may appear during daily use (such as invalid data entries), and general troubleshooting steps for common issues. Consult this section first if the indicator displays a warning message or behaves unexpectedly.

### 9.1 Critical Errors

Critical errors represent hardware failures or configuration issues that prevent the indicator from weighing. When a critical error is active, the specific alert message will replace the title on the main weight display and will also be listed in the system info error screen for diagnostics.

Inside the enclosure, located on the display board, is a red, error LED that acts as a secondary error notification guide. This LED flashes specific patterns to help technicians identify active faults even if the screen is not immediately visible.

#### 1. Calibration Not Set

- **Description:** The unit does not have valid calibration data in its memory. The indicator cannot weigh until a successful calibration is performed.
- **Error LED Status: 1 Flash** (Repeats every 2 seconds).
- **Likely Causes:**
  - This is a new unit that has not yet been calibrated.
  - The previous calibration attempt failed or was rejected.
  - Memory corruption has occurred.
- **Solution:** Contact Scaleton Industries support to perform a full calibration.

#### 2. Base Input Error

- **Description:** The indicator is not receiving a valid signal from the scale base. The signal is either missing or physically out of range (greater than  $\pm 4,000,000$  bits).
- **Error LED Status: 2 Flashes** (Repeats every 2 seconds).
- **Likely Causes:**
  - Scale base input cable is disconnected.
  - Scale base wiring is cut or damaged.
  - Scale base input cable wiring is incorrect.
  - Scale base is severely overloaded.
  - Scale base load cells are damaged.

### 3. System Error

- **Description:** The system detects a hardware malfunction in the control or display board.
- **Error LED Status: 3 Flashes** (Repeats every 2 seconds).
- **Likely Causes:**
  - Internal component failure.
  - Short circuit or hardware damage on the control or display board.
  - Damaged ribbon cable.
- **Solution:** Power cycle the indicator. If the error persists, contact Scaleton Industries for support.

## 9.2 Operational Errors

These messages appear during configuration or standard operation when an invalid value is entered or incorrect operation is performed. They indicate a procedure error rather than a critical configuration or hardware error.

### 1. “TARE > MAX GROSS”

- Screen Header: “TARE ERROR”
- Cause: You attempted to enter a manual tare value that is higher than the scale's calibrated max gross.
- Solution: Enter a tare value that is less than the max gross weight.

### 2. “NET > GROSS”

- Screen Header: “TARE ERROR”
- Cause: You attempted to enter a manual net weight that is higher than the current gross weight on the scale. This is mathematically impossible as it would result in a negative tare value.
- Solution: Ensure the net weight you are entering is lower than the current weight on the scale.

### 3. “GROSS < 0”

- Screen Header: “TARE ERROR”
- Cause: You attempted to access the edit net menu while the current gross weight on the scale is negative (below zero).
- Solution: Ensure positive weight is applied before attempting to edit net weight.

### 4. “NOT CALIBRATED”

- Screen Header: “TARE ERROR”
- Cause: You attempted to enter the tare menu, but the unit has not yet been calibrated.
- Solution: Calibration must be complete to access tare.

### 5. "WRONG PASSWORD"

- Screen Header: "ERROR"
- Cause: The incorrect security code was entered when trying to access the calibration procedure.
- Solution: Contact Scaleton Industries support.

### 6. "INCORRECT CAL"

- Screen Header: "CAL ERROR"
- Cause: The calibration was rejected because the signal difference between the zero reading and the weight reading was too small, or the base input signal during weight calibration was lower than the base input signal during zero calibration.
- Solution:
  - Ensure you are following the calibration steps properly.
  - Ensure you are using a proper calibration weight.
  - Check that the load cells are wired correctly (signal polarity may be reversed).
  - Ensure the scale platform is not binding or obstructed.

### 7. "MAX GROSS = 0"

- Screen Header: "CAL ERROR"
- Cause: You entered 0 for the max gross weight setting during calibration.
- Solution: Enter a valid non-zero capacity.

### 8. "CAL WEIGHT = 0"

- Screen Header: "CAL ERROR"
- Cause: You entered 0 for the calibration weight value.
- Solution: Enter the actual value of the test weights applied to the scale.

### 9. "SG = 0"

- Screen Header: "ERROR"
- Cause: You entered 0.000 for the specific gravity setting. This is not allowed because it is used as a divisor in volume calculations.
- Solution: Enter a valid specific gravity (1.000 for water).